

Hierarchical and Flat-Based Hybrid Naming Scheme in Content-Centric Networks of Things

Sobia Arshad, *Member, IEEE*, Babar Shahzaad, Muhammad Awais Azam^{ib}, Jonathan Loo, Syed Hassan Ahmed^{ib}, *Member, IEEE*, and Saleem Aslam

Abstract—Information-centric networking (ICN) approaches have been considered as an alternative approach to TCP/IP. Contrary to the traditional IP, the ICN treats *content* as a first-class citizen of the entire network, where *names* are given through different naming schemes to *contents* and are used during the retrieval. Among ICN approaches, content centric networking (CCN) is one of the key protocols being explored for Internet of Things (IoT), names the contents using hierarchical naming. Moreover, CCN follows pull-based strategy and exhibits the communication loop problem because of its broadcasting mode. However, IoT requires both pull and push modes of communication with scalable and secured content names in terms of integrity. In this paper, we propose a hybrid naming scheme that names contents using hierarchical and flat components to support both *push* and *pull* communication and to provide both scalability and security, respectively. We consider an IoT-based smart campus scenario and introduce two transmission modes: 1) unicast mode and 2) broadcast mode to address loop problem associated with CCN. Simulation results demonstrate that proposed scheme significantly improves the rate of interest transmissions, number of covered hops, name aggregation, and reliability along with addressing the loop problem.

Index Terms—Content naming, content-centric networking (CCN), information-centric networking (ICN), Internet of Things (IoT), push-support.

I. INTRODUCTION

DURING 2008–2009, number of connected devices exceeded the number of humans on Earth for the first time and had introduced the concept of glorious Internet of Things (IoT) [1]. With the proliferation in the number and the

usage of these low-cost and low-power connected devices in the form of mobile devices, RFID tags, sensors, actuators, and smart gadgets has further assisted in the transformation of IoT from concept to reality. IoT is also considered to be the main force behind the 4th industrial revolution which helps to build smart infrastructures [2]. IoT devices are equipped with sensing, processing, actuating and transmission capabilities. When these IoT devices connect to the Internet along with human Internet users, production of huge amount of useful data is an obvious outcome [3]. Management of these billions of IoT devices and huge amounts of the data they produce (through TCP/IP networking model) is facing many issues [4].

Before IoT era, the researchers were trying to address the issues of traditional TCP/IP model and proposing modifications to make it suitable for future Internet. Although many intermediate solutions were proposed like content delivery networks (CDNs) but these efforts resulted in a known concept of ICN. In addition, Internet users found more interested in content from Internet (i.e., it can be any host) rather than communication with any specific host. In IoT era, ICN has appeared as a promising solution of the issues of TCP/IP model. ICN consider “content” as main element of the Internet architecture which triggered several projects including DONA, named data networking (NDN), content centric networking (CCN), MobilityFirst, CONET, PURSUIT, NetInf, and CURLING [5]. Among these, CCN is a prominent proof of concept [6].

Basically, CCN is a pull-based (i.e., consumer-driven) communication model where service subscriber gets data irrespective of location of content provider (publisher) only when it is subscribed for a content. CCN communication is based on two packets “Interest” and “Data” which are used to request and transfer the content, respectively. CCN can run on any network-enabled device because of its content-centric nature. CCN routers uses three data structures namely pending interest table (PIT), forwarding information base (FIB), and content store (CS). PIT keeps track of entries that are waiting to be satisfied. CS stores a copy of requested data to ensure data availability. FIB saves interface information against any name received or generated in the Interest packet. If the Interest is not satisfied at all, there will be no entry in the FIB [7].

In CCN, content name is assigned by the publisher of the content and this name helps to cache the content at intermediate device. Fig. 1 shows the basic content propagation and retrieval used in CCN. There are two general CCN naming schemes: 1) hierarchical and 2) flat [5].

Manuscript received September 15, 2017; revised November 5, 2017; accepted January 3, 2018. Date of publication January 11, 2018; date of current version April 10, 2018. This work was supported by the Computer Engineering Department, University of Engineering and Technology, Taxila, Taxila, Pakistan, under a Full-Time Research Scholarship and Research in Close Collaboration with the University of West London, U.K. under Grant UET/ASR&TD/RG-1003. (*Corresponding author: Sobia Arshad.*)

S. Arshad and M. A. Azam are with the Department of Computer Engineering, University of Engineering and Technology, Taxila, Taxila 47080, Pakistan (e-mail: sobia.arshad@uettaxila.edu.pk; awais.azam@uettaxila.edu.pk).

B. Shahzaad is with the Department of Computer Science, University of Management and Technology, Sialkot, Pakistan (e-mail: babar.shahzaad@skt.umt.edu.pk).

J. Loo is with the School of Computing and Engineering, University of West London, London W5 5RF, U.K. (e-mail: jonathan.loo@uwl.ac.uk).

S. H. Ahmed is with the Department of Electrical and Computer Engineering, University of Central Florida, Orlando, FL 32816 USA (e-mail: sh.ahmed@ieee.org).

S. Aslam is with the Department of Electrical Engineering, Bahria University, Islamabad 44000, Pakistan (e-mail: saleem.buic@bahria.edu.pk). Digital Object Identifier 10.1109/JIOT.2018.2792016

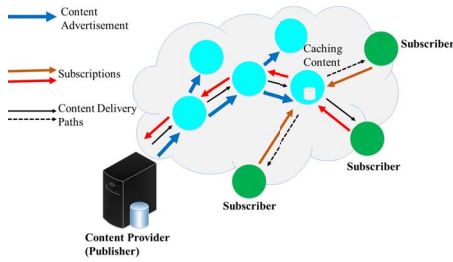

Fig. 1. Basic content propagation and retrieval in CCN.

The *hierarchical naming* is adopted in both famous CCN and NDN architectures. The hierarchical naming assigns content name in human-readable fashion using the hierarchical structure. It is similar to URL such as locating a Web page with a given URL (e.g., /www.uetaxila.edu.pk/content/a.avi). “/” is a separator between the contiguous components of a name in the given example. The advantages of hierarchical naming include compatibility with current system and aggregation of data to minimize the routing information while improving the efficiency to search in a routing table. On the other hand, the disadvantage includes the variable length of the component name. Due to variable component name length, content name becomes long and it becomes very difficult to remember the long names [8]. The *flat naming* is utilized by the future network ICN architectures like NetInf, MobilityFirst, and DONA [5]. Flat name is generated through cryptographic hashing of the content or its subcomponent or its attributes. This naming procedure is unique in the sense that it assures location independence, application independence and global uniqueness. However, it slows down the aggregation mechanism (just like IP addresses aggregation) which increases the size of routing tables and their entries. Furthermore, the flat names may become unreadable which requires an additional system for the classification of readable and nonreadable names.

More specifically, CCN-based IoT content naming mechanism needs support for: global unique information retrieval, location independence, security, push-support, and human-readability. Push support is required when any subscriber of application wants to perform any action on content producer (i.e., sensors). Thus naming the contents by incorporating above features is one of the key expectations from CCN-based architecture design for IoT [9] and the main motivation behind this paper. Our proposed hybrid naming scheme combines both hierarchical and flat naming schemes from ICN models, add a subname (i.e., *task*) in content name to support both push and pull communication modes and appends hashed value of content to enhance security while maintaining integrity about content and its provider.

The main contributions of this paper can be summarized as follows.

- 1) We propose a hybrid content naming scheme for CCN that incorporate both hierarchical and flat ICN naming schemes for IoT-based smart campus (SC).
- 2) We introduce a sub part in the content name to support both pull and push style communication among IoT devices.

TABLE I
COMPARISON OF MEMORY FOOTPRINTS FOR HARDWARE
AND IoT OPERATING SYSTEM

IoT Operating System: RIOT			
Module	Developing Board /Processor	ROM (KB)	RAM (KB)
CoAP+RPL+6LoWPAN	Cortex-M3	48.5	10.7
NDN		15.6	2.7
CoAP+RPL+6LoWPAN	ARM7	78.6	8.8
NDN		22.2	3.5
RPL+6LoWPAN	MSBA2	53.412	27.739
CCN-Lite		16.628	5.112
IoT Operating System: Contiki			
Module	Developing Board /Processor	ROM (KB)	RAM (KB)
CoAP+RPL+6LoWPAN	ARM7	61.3	16.5
CCN		13	5.7
RPL+6LoWPAN	RedBee-Econotag	52.131	21.057
CCNx		13.005	5.769

- 3) We consider IoT-based SC having heterogeneous IoT nodes (i.e., both static and mobile) to evaluate proposed naming scheme and achieve significant performance in terms of interest satisfaction rate (SR), number of transmissions and latency, name-aggregation, and security (i.e., integrity) over existing schemes [10], [11].

The rest of this paper is organized as follows. Section II discusses the preliminaries and related work. Section III describes the proposed naming scheme while its investigation is discussed in Section IV. Performance evaluation along with results is discussed in Section V and we conclude the work with tentative future aspects in Section VI.

II. PRELIMINARIES AND RELATED WORK

Here, we discuss few key motivations of considering CCN for IoT followed by the latest literature on naming schemes.

A. CCN-Based IoT in Nutshell

IoT environment have both static (e.g., sensors and machines in smart home, e-health, and in smart industry) and mobile devices (i.e., connected smart vehicles). Most of IoT devices are low-power and low-cost which needs to be energy-efficient, secure, reliable, interoperable, and scalable. While, in CCN, as data publisher apply naming to the content independently from its own location, this feature provides decoupling of publisher and subscriber and enables easy caching. Exploiting the CCN for IoT can provide aforementioned advantages over traditional TCP/IP architecture [9].

Furthermore, most of the IoT applications, contents and services require more, than only the communication between specific devices. As CCN disseminates contents and enables services through naming and this makes, naming the contents (i.e., instead of IoT devices) oftenly more significant. Next, with inherent caching and processing, IoT constraint-oriented devices can benefit even more due to their low-power nature. As in IoT environment, it is necessary to disseminate and retrieve content to multiple places with less number of transmissions, therefore caching and processing contents in the IoT local networks is important to save device battery

TABLE II
SUMMARY OF RELATED WORK. HN IS FOR HIERARCHICAL NAMING AND FN IS FOR FLAT NAMING

Ref.	Objective	HN	FN (Security)	Push Support	Remarks
[10]	ICN based naming for Smart Home	✓	✗	✓	Only Static Nodes considered and Not for hybrid IoT environment
[11]	ICN based Naming for VANETS	✓	✓	✗	Only Mobile Nodes considered and Not for hybrid IoT environment
[13]	ICN based Naming for smart building	✓	✗	✗	Only limited Static Nodes considered and Not for hybrid IoT environment
[14]	ICN based Naming for under water	✓	✗	✗	Only limited Static Nodes considered and Not for hybrid IoT environment
Proposed Naming Scheme	ICN based Naming for Smart Campus	✓	✓	✓	Suitable for IoT environment with both static and mobile nodes

and network bandwidth. In addition, during content request and response, caching helps to reduce delay in the result of local cache access. Moreover, caching the contents enhances the *data availability* where devices oftenly run out of power battery. In short, CCN approach for IoT can be as follows.

- 1) Significantly decrease the complexity of auto-configuration methods through naming the IoT devices, contents and services in comparison to TCP/IP (i.e., a layered protocol stack) as TCP/IP protocols including DNS, CDN, TCP, routing, and IP are merged in to one CCN [12].
- 2) Offer number of opportunities to powerfully factorize functionalities (i.e., buffering and caching for the data availability and energy efficiency [15], [16]).
- 3) Achieve lesser memory footprint in comparison to 6LoWPAN/RPL/IPv6 [16]. In Table I, it can be clearly seen that ICN projects exhibits less memory as compared to TCP/IP-based solutions for IoT.

B. Related Work

Most of the IoT application scenarios follow naturally CCN model features. For example, IoT sensor content retrieval and mobile content updates use naming the contents and decoupling between subscriber and publisher. These IoT scenarios get further improvements through CCN in-network processing, caching, and light-weight memory footprints. Actually, CCN concept and its design is more feasible for IoT wild deployments in both energy-efficient and memory-efficient manner.

The naming scheme presented in [10] employs the hierarchical naming mechanism. However, this scheme does not ensure security to critical information parts or sub parts. Furthermore, the authors consider only the static nodes which limit the applicability of their naming scheme in an environment where both static and mobile nodes are present. Bouk *et al.* [11] introduced naming scheme for vehicular ad hoc networks. They only worked for vehicles. However, they did not consider static nodes and push communication style. Bouk *et al.* [14] implemented NDN hierarchical naming for underwater monitoring having static nodes without security and push support. Li *et al.* [17] compared both MobilityFirst and NDN models based on two scenarios (i.e., static and mobile). However, the static and mobile scenarios are addressed separately. Moreover, regarding mobility support, names of content remains same in

TABLE III
LIST OF KEY TERMS USED

Key Terms	Meaning
CCN	Content Centric Networking
PIT	Pending Interest Table
FIB	Forwarding Information Base
CS	Content Store
CO	Content Object

CCN because it supports data access through content names (rather than the IP addresses), this also helps mobile users to access the data continuously even if the published content is unavailable during the content flow. Meisel *et al.* [18] argued that current architecture of the Internet and its protocols are not suitable for an extremely mobile environment like MANET.

In summary, all of the above presented naming schemes addressed issues with a major focus on static devices without security and push support. Summary of most relevant literature along with important comparative factors is presented in Table II. Contrary to the existing naming schemes and considering the fact that IoT needs to be able to send data and to be controlled remotely, our proposed naming scheme incorporates the security and push communication aspects in the naming mechanism for both static and mobile nodes.

III. PROPOSED NAMING SCHEME

In this section, we describe the design of proposed hybrid naming scheme. We combine the positive attributes of both hierarchical and flat ICN naming schemes and present a novel hybrid name scheme which has two key parts: 1) hierarchical component and 2) flat component. We also discuss about the processing of interest and data messages following with the tentative advantages of proposed naming scheme. List of key terms used in this paper are listed in Table III.

A. Hierarchical Component

This component is generated by following uniform resource identifier syntax having three subcomponents: 1) domain name; 2) location; and 3) task. Like NDN naming scheme, forward slash / is used as a separator between the subcomponents of the hierarchical component. These all three subcomponents are mixed to form hierarchical component (e.g., domain-name/location/task can have values of uettaxila/CP/DC/action: on as shown in Fig. 2. Table IV describes the definitions for

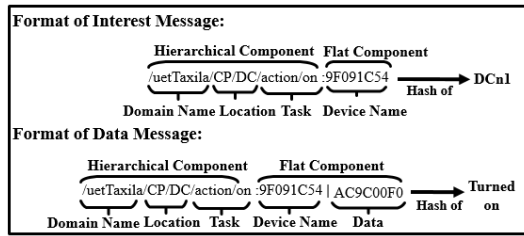

Fig. 2. Example of proposed naming scheme.

TABLE IV
DESCRIPTION OF THE COMPONENTS OF PROPOSED NAMING SCHEME

Components	Description
Domain Name	It is used to represent the name of the organization or building
Location	It is used to represent the location of the node where to send the Interest message and from where to retrieve the Data
Task	It is used to represent the tasks that can be performed like sensing, action, etc.
Device Name	It is the flat part which is used to represent the device uniquely by encrypting its name
Data	It is also flat part which encrypts the data to ensure its integrity

these subcomponents. The hierarchical component works as a prefix to: 1) locate the domain name; 2) information retrieval site; or 3) the location of task to be performed. Task component represents the type of task which has two types: 1) action and 2) sensing. This representation provides name aggregation to optimize the routing table. The entries with a matching prefix are aggregated to minimize the number of entries in the routing table. An identifier, assigned to each aggregated entry using the arrival face of that entry, differentiates them. When an Interest is satisfied, it sends the retrieved Data to all the identifiers of an aggregated entry and then removes them from the routing table.

B. Flat/Hash Component

This hierarchical component is further combined with second (flat) component using “:” as separator. The flat component deals with device name and data. It has a limited length of 32-bits, which overcomes the problem of long hierarchical names. It has low aggregation but it ensures names uniqueness. To secure the device and data generated, FNV-1a hash [19], a noncryptographic hashing algorithm is utilized. For example, considering the Computer Engineering Department of University of Engineering & Technology (UET) Taxila, Node1 ($n1$) is in Data Communication (DC) Laboratory then the pseudo-code for the algorithm is as follows:

```

h = offset-factor for each octet to be hashed
h = h xor octet
h = h * prime-factor
return h

```

where “h” represents the hash value while octet represents the octet of data. Offset-factor and prime-factor depend upon the length of hash. The values of offset-factor and prime-factor for 32-bit hash are 16777619 (0x01000193)

Algorithm 1 Processing of Interest in the Proposed Naming Scheme

Input: Interest [Domain Name, Location, Task, Device Name]
Output: Data [Domain Name, Location, Task, Device Name, Content]

- 1: Generate Interest at Sink Node.
- 2: Assign Identifier 0 to PIT at Sink Node and Send Interest to Neighboring Node(s).
- 3: **repeat**
- 4: **if** Content Not in CS then
if Device Name Not in PIT **then**
Add [Location, Task, Device Name, Face] in PIT.
Initialize Timer (s).
Forward Interest using FIB.
else
Drop Interest.
end if
else
Send Data.
end if
- 5: **until** Data Sent or Interest forwarded to Last Node(s)
- 6: Send Data to requesting Intermediate Node.

Algorithm 2 Processing of Data in the Proposed Naming Scheme

Input: Data [Domain Name, Location, Task, Device Name, Content]
Output: Data[Receive Data at Sink Node]

- 1: Send Data to Neighboring Node(s).
- 2: **repeat**
- 3: **if** Name in PIT **then**
if Face has 0 Identifier **then**
Sink Node Receives Data.
else
Cache Data in Intermediate Node(s).
Forward Data to Next Node.
Remove [Location, Task, Device Name, Face] from PIT
end if
else
Drop Data.
end if
- 4: **until** Data delivered to Sink Node
- 5: Remove Identifier 0 from Sink Node.

and 2166136261 (0x811C9DC5), respectively. The hash for DCn1 is 0x9F091C54 [20].

Moreover, vertical bar “|” is used as a separator between Interest message content name and data message content.

C. CCN-Based Interest and Data Message Processing

Algorithm 1 describes the reception and forwarding of Interest message in the network. When any sink (consumer) node generates interest packet to get any named-content, this sink node adds interest with identifier 0 in its own PIT and forwards this Interest toward neighboring nodes. Then in the network, every node checks this specific interest in their CS and transfer data if find. If Interest is not found in CS then it checks in PIT and if found then it drops this Interest (It means that the request is already arrived for this Interest). If Interest entry is not found in PIT, then to add new entry of this Interest its location, task, device Name, and face (application name) is added along with initializing timer. And Interest is forwarded using FIB. Above process is repeated until data is sent or Interest is sent to last node in the network. Algorithm 2 describes the delivery of data in response to received Interest. When any node finds corresponding data to Interest, this node forwards this data toward its neighboring nodes. And every

neighboring node checks this data packet name exists in PIT to deliver the data. If it does not find corresponding entry, then this node drops the data (this node is not that who sent the request). If PIT entry exists then, it further checks that the packet has 0 identifier, the node has already received data. Otherwise, if this node is not consumer node then after caching the data it forwards to next node and it removes this Interest relevant data from PIT. This whole procedure is repeated until data is delivered to sink (consumer) node. After receiving data, sink node stores and removes its identifier as 0.

D. Advantages of the Proposed Naming Scheme

We present some key advantages of the proposed naming scheme, which indicates its feasibility and viability for IoT environment and compared against related work in Table II.

1) *High Aggregation*: Name-aggregation is very useful for both reducing the number of entries in the routing table and efficient lookup operation. The hierarchical part of the proposed scheme provides great aggregation; this is the one reason to use it first. For example, consider two interests having same prefix such as /uetTaxila/CP/DC/sensing:0x9F091C54 and /uetTaxila/CP/DC/action/on:0x9F091C54. As the prefix/uetTaxila/CP/DC/ is same for both interests, so they will be aggregated in the routing table, which will minimize the number of entries in the routing table and reduce memory size of the router.

2) *Fixed Length*: The hierarchical names, which are composed of different parts can have variable length. In return, this affects the performance in terms of query speed in routing table or forwarding table. Therefore, the names should be of fixed length. The proposed scheme has been restricted to a maximum of 102 bytes for both Interest packet and Data packet. Out of these 102 bytes, last 4 bytes (32-bits) of Interest message and last 8 bytes (64-bits) of Data are reserved for flat part. Algorithms, which depend upon the length of query, can run efficiently if the length is fixed.

3) *Scalability*: The proposed naming scheme considers the concept of hierarchical naming which inherits high scalability (due to high name aggregation) as compared to the current IP-based communication systems.

4) *Security*: Proposed scheme tends to provide high level of security in form of integrity due to the use of flat component which is hashed (of device name and data message value) by FNV-1a hash algorithm.

5) *Push Support*: In IoT, when main application server needs to push any command toward data providers (i.e., sensors) then proposed naming scheme's subcomponent *task* with the value of *action* provides push support.

In the following section, the proposed naming scheme is investigated for IoT-based application scenario.

IV. INVESTIGATION OF THE PROPOSED NAMING SCHEME IN IoT DOMAIN

To investigate the proposed naming scheme in IoT domain, we consider SC as a reference model for IoT scenarios. An SC can include temperature sensors to exhibit important feature of temperature sensing. Temperature sensing feature can be used

to control and monitor both laboratory and classrooms through the implementation of different actions like switching the air conditioners, computers, and different sensors on and off. A CCN-based SC server (sink node) pulls (fetch) the data from sensors by sending Interest messages at regular intervals of time and then accordingly push (send) commands to perform above-mentioned actions.

There are different modes available for transmission of packets from source to the destination like unicast, multicast, and broadcast.

A. Smart Campus Scenario Description

A hybrid model with both type of nodes (i.e., static and mobile) have been employed to analyze the efficiency in terms of sending and receiving of Interest and data packets. Fig. 3 shows the simulation setup for the investigation of proposed naming scheme with different number of nodes as reference models. The devices used in scenario are sensors, routers, and mobile data carriers for delivery of Interest messages to static nodes that are out of range. In reference model, there are eleven departments named Civil (CE), Mechanical (ME), Electrical (EE), Electronics (EC), Computer/Software (CP/SE), Transportation (TRE), Transport Office (TR), Library (LB) and Admin Block (AD), Telecom/Computer-Science Dept. (TE/CS), and Industrial/Humanities Department (IE/HU). In each building, total five devices are placed at different locations for sensing temperature or switching on/off devices as mentioned in Interest packet. Out of these five devices, four are Zigbee-based Temperature sensors and one is WiFi access point. Eight mobile data carriers are used which will travel on specific routes to forward and collect the requests and data, respectively. A sink node (WiFi) as SC server is placed in the CE because this is located at the center of all other nodes. Two mobile nodes and all the nodes in CE are placed in the range of sink node as shown in Fig. 3. All nodes except sink node work as a source of required content. We vary number of mobile nodes from two to eight and mobile nodes are used to forward Interest message toward static nodes deployed in other departments. In the shown scenario with eight mobile nodes, the sink node generates an Interest; the two mobile nodes receive it and start moving toward the other two (in both directions) that are in idle state.

Second scenario (right side of Fig. 3) having only static nodes is used for comparison purposes. If a node cannot satisfy the Interest, it forwards to other nodes in its range. This chain is used to forward the Interest from the sink node to last source node in the given scenario.

B. Communication Loop Problem Solution

As CCN implements broadcast mode of transmission in order to send and receive Interest and data packets, respectively. This broadcast mode of communication presents a problem called "loop problem." When a sink node transmits an Interest to all nodes in the network range and stores an entry in its own PIT. If the receiving nodes cannot satisfy the incoming Interest, they store that Interest in their PIT and then forwards to other nodes. In that case, whether an Interest is satisfied or

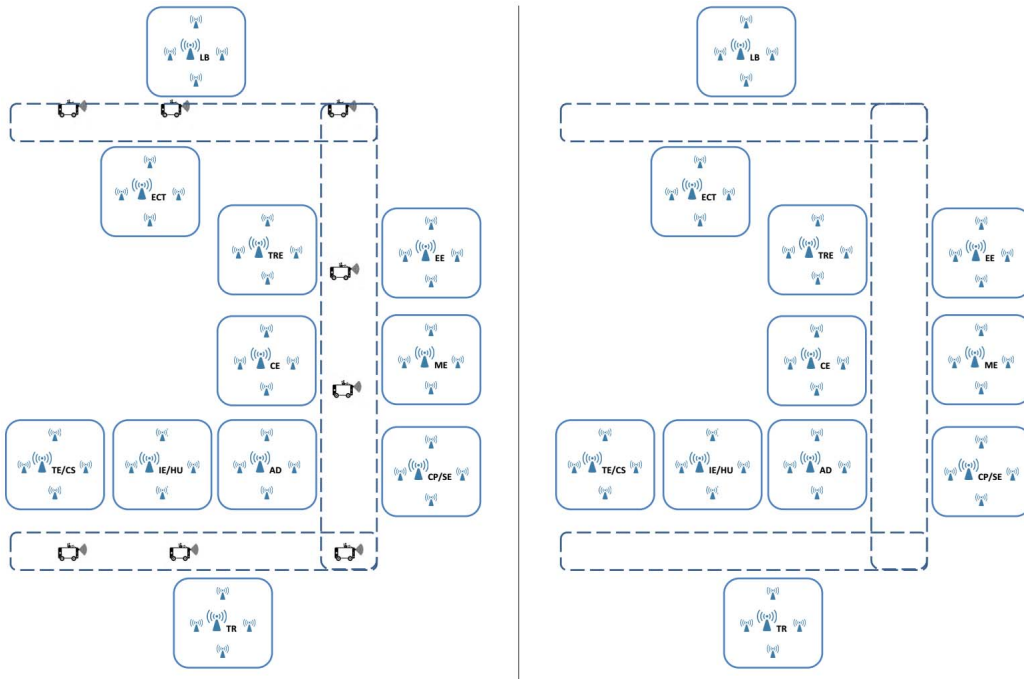

Fig. 3. Reference model for proposed naming scheme. Left side::with eight mobile nodes and 55 static nodes and right side::only static nodes, LB = Library, ECT = Electronics, EE = Electrical Eng, TRE = Transportation Engg., ME = Mechanical Eng., CE = Civil Eng., CP/SE = Computer/Software., AD = Administration Block. TE/CS = Telecom/Computer-Science, IE/HU = Industrial/Humanities, and TR = Transport Section.

not, it remains in PIT of the sink node, which creates a loop. For example, if a sink node has two neighboring nodes and it broadcasts an Interest toward both of them. If the Interest is satisfied on the first node but not on the second. Then the first node sends content object (CO) toward both sink node and second node, while second forwards the Interest by broadcasting again toward the first node and remaining neighboring nodes. Both first node and sink node will receive same interest again. This situation creates a communication loop [21]. To resolve this problem, we use the concept of unicast using multihopping along with broadcast. For example, in the reference model, initially, sink node broadcasts an Interest message to all neighboring nodes, while multihop unicast is implemented for both to deliver the Interest packet to nodes in the department (on the basis of prefix mentioned in hierarchical component) and send data packets back to the sink node.

C. Tree Structure of the Proposed Naming Scheme

We illustrate an example of proposed naming scheme (details in Table IV) through tree structure shown in Fig. 4. We can easily extend this by adding new locations and types of task. For example, an action can be performed on computers/air conditioners by sensing the temperatures of said location. An Interest message, e.g., /uetTaxila/CP/DC/action/on:C60B9850 is used to turn on the PC1 in DC Laboratory of Computer Department, UET, Taxila. After the Interest is satisfied, a data packet will be sent back consisting of the name same as Interest and a 32-bit hashed value of a short string representing that the Interest has been satisfied or not. If the Interest is not satisfied, the payload of data packet may have a specific hashed string to represent any malfunctioning of computer.

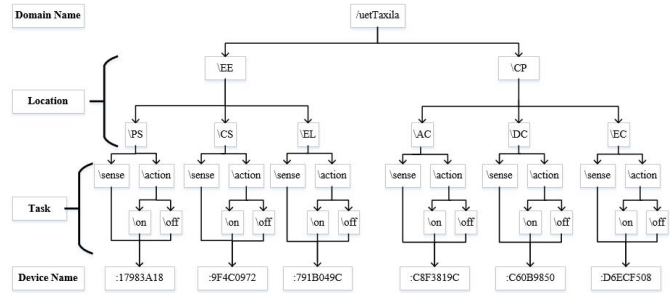

Fig. 4. Tree structure for proposed naming scheme.

D. Processing of Interest and Data Message

Fig. 5 describes the exemplary scenario to highlight the working of the proposed scheme. For the sake of simplicity, it shows only the nodes that are involved in communication. In this example, the sink node generates an Interest message and broadcasts it to all the nodes in its range. MN1 receives the Interest message and stores it in PIT. If there is another entry with the same prefix, then it discards the Interest and adds a face identifier to the existing entry representing the original source of the Interest packet. Once the Interest is stored in PIT, node forwards it to other nodes in the connectivity. A mobile node is used for propagating the Interest in the network so that the nodes at a distance can receive the Interest message and perform operations accordingly. Fig. 6 shows different steps to understand the working of example scenario. Following are the steps of Interest generation and satisfaction process in the reference model.

- 1) As sink node is placed in CE department having one mobile node MN1 and all static nodes of CE department are in its range. Sink node generates an Interest

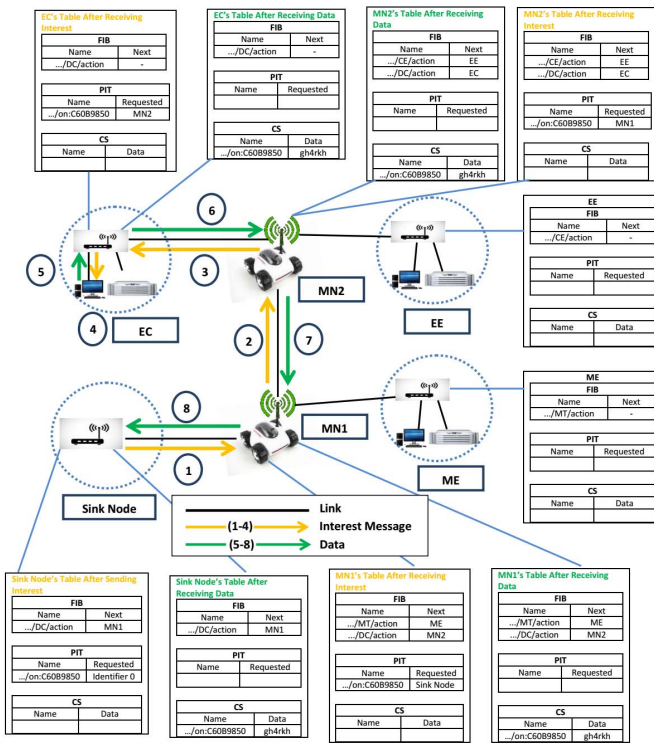

Fig. 5. Working of proposed naming scheme in reference model.

with name `/uetTaxila/EC/DC/action/on: C60B9850`. It is stored in the PIT before propagation to other nodes connected to sink node. An identifier 0 is attached to the Interest stored in PIT of sink node indicating that it is the original requester of Data.

- 2) Sink node transmits (broadcasts) generated Interest message to all the nodes in its range (MN1 and all static nodes of CE). As in this case, static nodes which resides in CE, discard this message by looking at the prefix. If the request is to retrieve data from nodes in other departments, mobile nodes help to forward the Interest message to nodes that are not in direct range of sink node. Therefore, MN1, after receiving Interest message from sink node, performs a long prefix match on FIB to check either this entry is already available or not. In the case of absence, MN1 starts moving on the specified route and forwards the Interest to all the faces stored in its FIB at regular intervals of time. But if the Interest is meant to perform a task in CE department where sink node resides, then Interest is processed without the interference of any mobile node. CE static node receive Interest and send corresponding data message after performing specified action in unicast mode.
- 3) Nodes at EE and ME do not process the Interest because their prefix does not match with the Interest prefix. The mobile node, MN1 forwards the Interest message to MN2 after entering in its range and start moving toward the EC, which is the destination location in this case.
- 4) Five static nodes in EC department receive the incoming Interest but only one can perform the action requested in the Interest message, i.e., turning on the computers in

DC Laboratory in Electronic Department. It is because the nodes residing within the department implements the unicast mode of transmission.

- 5) After the Interest is satisfied, a data message with CO is sent back to requesting node. The CO is `/uetTaxila/EC/DC/action/on:C60B9850lgh4rkh`, where the prefix name of both the Interest message and CO message is same. The last hash/flat component of data message contains the actual CO value.
- 6) PIT of EC removes the Interest from the list of unsatisfied interests, stores the data in its CS, and then forwards to MN2.
- 7) CO message is replicated at intermediate nodes, MN2 and MN1, for fast retrieval of data in future.
- 8) The reference identifier 0 in PIT is removed, indicating that Interest has been satisfied. Finally, CO message is delivered to the sink node and stored in its CS indicating that action is performed successfully.

If there is a need to perform an action on a different number of nodes having same name prefix, then a prefix is sent as a name in the Interest messages instead of specifying a node. An Interest message with name `/uetTaxila/EC/DC/action/on` will turn on all the computers in DC Laboratory of EC department.

V. PERFORMANCE EVALUATION

In this section, we discuss performance evaluation of proposed naming scheme considering scenarios of SC shown in Fig. 3.

A. Simulation Environment

We use 55 static nodes and vary the number of mobile nodes (from two to eight) to cover the total area for exchange of Interest and data messages among sink node and source nodes. All nodes are arranged in the form of considered scenario. CCNx implementations are used in Contiki OS-based Cooja simulator [21]. We implemented proposed naming scheme in CCNx implementations in Contiki OS-based Cooja simulator installed in a Linux Ubuntu running on virtual machine. A core-i5 PC with 4 GB RAM is used for implementation and performance evaluation. CCNx is modified in accordance with the proposed naming scheme. CCNx hierarchical naming is concatenated with flat naming by implementing a separate function to calculate hash (pseudo code is given above). Simulations are run for 1600 s and Tmote Sky type motes are used. We use random-waypoint mobility model (RWMM) mobility plugin in this simulation for mobile nodes to move in particular direction. RWMM has the following input parameters: node number, time in seconds, x -coordinate, and y -coordinate. The node number is not the Rime address and it starts from "0" means the "node 0" represents the "mote 1." The coordinates have value in meters. Rest of the simulation parameters that help in evaluating the proposed technique through a series of simulations in Contiki-based Cooja Simulator are summarized in Table V. Though fixed number of nodes are considered in these scenarios but this implementation can also be validated on a large scale as the proposed scheme presents high scalability.

TABLE V
SIMULATION PARAMETERS

Parameter	Value/Name
Communication Stack	CCN
Radio Medium	Unit Disk Graph Medium (UDGM): Distance Loss
Topology Size	200*350
Number of Nodes	55 Static, 8 Mobile
Number of Transmissions	200
Tx Range	40 meters
Interference Range	60 meters
Packet Size	102 bytes
MAC Layer	IEEE 802.15.4
Network Driver	ccn_driver
MAC Driver	csma_driver
Radio Duty Cycling Driver	sicslowmac_driver
Radio Driver	cc2420_driver
Mote Type	Tmote Sky
Speed	No limit speed
Simulation Time	1600 s
Mobility Model	Random-Waypoint Mobility Model (RWMM) [22]

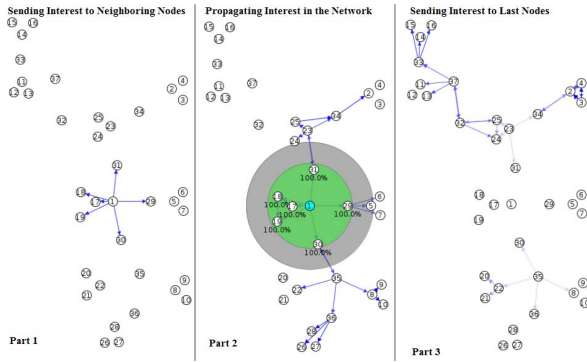

Fig. 6. Simulation scenario 1 (only static nodes).

To compare and show the worth of proposed naming scheme, three different scenarios (according to Fig. 3) are simulated in Cooja Simulator. Fig. 6 shows the simulation of only static nodes in which intermediate nodes forwards the Interest packets. The simulation of delivery of Interest message and data message using a different number of mobile nodes is shown in Figs. 7 and 8. Each figure contains three parts. Part 1 shows the start of simulation when the sink node sends the Interest to its neighboring nodes. If the nodes cannot satisfy the Interest, it is forwarded to other nodes using mobile nodes (part 2). Part 3 shows the case when the Interest is forwarded to the last nodes in the campus area and Interest forwarding is finished in this step.

B. Performance Metrics

The performance of proposed scheme is evaluated through the following metrics.

- 1) *Satisfaction Rate*: the ratio of total number of satisfied interests to total number of generated interests and can be calculated by using 1 as follows:

$$SR = \frac{\sum_1^N \text{Satisfied interests}}{\sum_1^N \text{Generated Interest}} * 100. \quad (1)$$

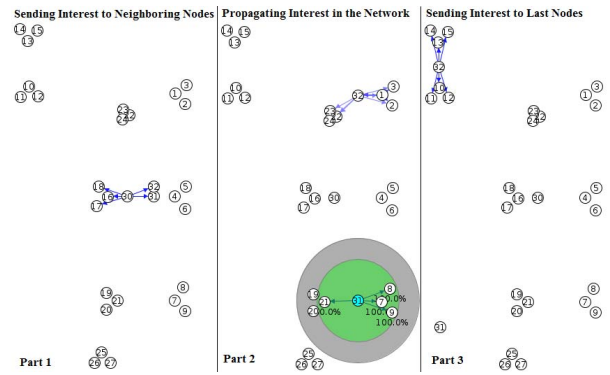

Fig. 7. Simulation scenario 2 (two mobile nodes).

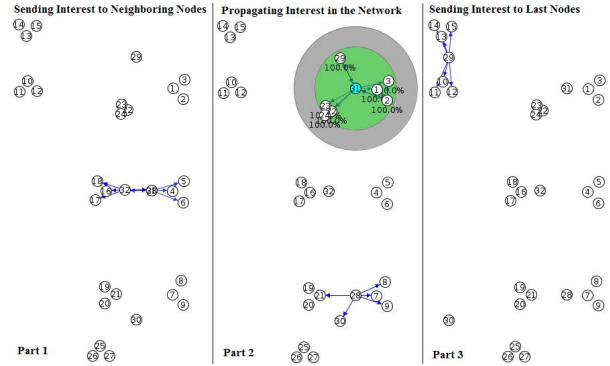

Fig. 8. Simulation scenario 3 (four mobile nodes).

where “n” is the total number of generated interests and “N” is the total number of satisfied interests.

- 1) *Average Latency*: is the ratio of total latency to the total number of packets received at sink node and can be calculated using

$$\text{Average Latency} = \frac{(\text{Total Latency})}{(\text{Total Packets Received})} \quad (2)$$

where total latency is the delay between Interest generation by sink node and its reception at the source node and can be calculated using

$$\text{Total Latency} = \sum_{n=1}^n (\text{Recv Time} - \text{Sent Time}). \quad (3)$$

The aggregation, number of hops, and Interest transmissions are computed using the log files generated for the simulations performed.

C. Results and Discussion

1) *Satisfaction Rate*: As static nodes implement only “broadcast mode,” and broadcast mode is the major reason of “communication loop” creation. Therefore, due to presence of communication loop, low SR is an obvious result and it is evident from Fig. 9 that static nodes exhibit low Interest SR.

As we stated above, we minimize communication loop in scenarios which have mobile nodes by implementing unicast mode in source nodes that reside in departments (i.e., source nodes send data to the requesting mobile node only instead of sending to all neighboring nodes). In this way, the percentage

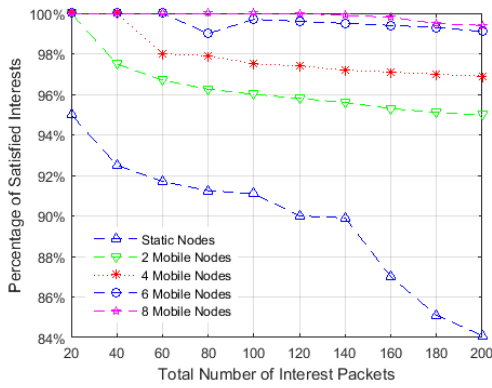

Fig. 9. Percentage of satisfied interests.

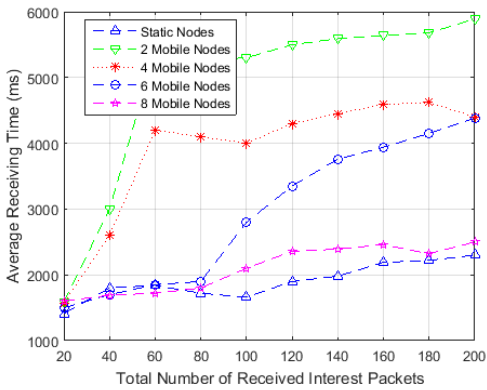

Fig. 10. Average delay of receiving Interest.

of the average number of interests satisfied, increased. This results in higher SR. For simulation, a number of interests are generated and their SR is over served by receiving the data requested. Mobile nodes shows better results because more average number of interests are satisfied before forwarding it to next mobile nodes and it is satisfied before its expiry in the given time period.

2) *Average Latency*: Average amount of delay in receiving the interests is higher in mobile nodes scenarios. Reason of this delay is the time which mobile nodes take while traveling from sink node to destination node. Although static nodes show less delay but they have more number of intermediate nodes between the sink and source nodes. Fig. 10 shows average latency computed for different number of interests in considered scenarios. The average delay in the scenarios with more than two nodes is not much higher because the sink node has some nodes in its range and some on very short distance. With the help of log generated for simulations, it is observed that more interests are satisfied before forwarding the Interest toward next mobile nodes which result less average delay in comparison to two mobile nodes which move back after completing the path.

3) *Transmission of Interest Packets*: The average number of transmissions are higher for static nodes because of the greater number of intermediate nodes and broadcasting mode. Every node, which receives the Interest packet, forwards the Interest to neighboring nodes if it does not have the required data. The mobile nodes work as carrier nodes to take the Interest packets to

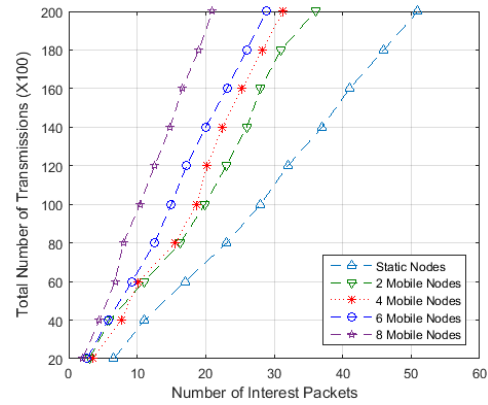

Fig. 11. Total number of transmissions (one sink node).

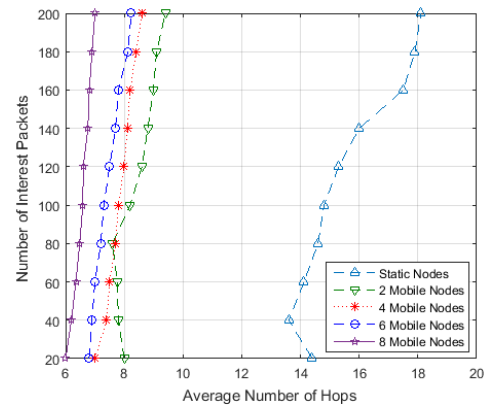

Fig. 12. Average number of hops.

nodes at a distance, minimizing the number of hops. They require less number of transmissions because only the mobile nodes work as intermediate nodes. Fig. 11 shows the comparison of transmission of Interest packets to reach the source node.

4) *Number of Hops*: Fig. 12 highlights and compares the performance of the proposed scheme in terms of number of interests across different hops. Different number of mobile nodes are presented for detailed investigation. In the case of static nodes, transmission of Interest and data packets is done with the help of intermediate static nodes only. The sink node broadcasts the Interest to its neighboring nodes. If the Interest is not satisfied, then it is propagated to next nodes until it is satisfied and data packet is received. For this reason, it has a greater number of hops in comparison to those where mobile nodes transmit Interest and data packets between the sink and last source node.

5) *Interest Aggregation*: The aggregation of interests in the intermediate nodes minimizes the size of routing table (PIT and FIB) and number of entries in it. Fig. 13 shows the percentage of interests aggregated in considered scenarios. It can be seen that flat naming shows very low aggregation as compared to hierarchical naming. Since, the proposed hybrid-naming scheme has both flat and hierarchical naming components, therefore it has higher Interest aggregation in comparison to only the flat naming scheme but less as compared to hierarchical naming. The interests with similar prefix require only one entry in the routing table and it is differentiated by the flat part, which

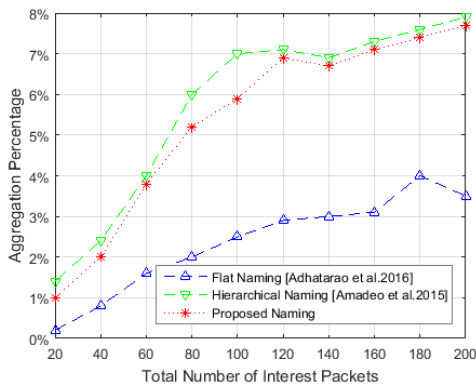

Fig. 13. Percentage of Interest aggregation.

is unique to every component. The results are obtained by observing that how many interests are generated and stored in the routing table on average.

VI. CONCLUSION

This paper presented and simulated a CCN model for IoT-based SC application, in which a hybrid naming scheme is proposed where contents are named through the use of both: 1) hierarchical and 2) flat naming schemes. The hierarchical component takes the domain name, location, task, and device name in URL style. By using “task,” push support is added in the native CCN protocol. The flat component is used to provide integrity and it is computed through the FNV-1a hash of the device name and data. The communication loop problem associated with CCN protocol is eliminated by implementing “unicast” protocol on the source nodes. Mobile IoT nodes are used for delivery of Interest and data packets to nodes that are not in the range of sink node. The proposed naming scheme is evaluated for IoT-SC having both static and mobile nodes and results revealed the significant gain in terms of success rate and number of transmissions of Interest packets, latency, number of hops, and interest aggregation. Furthermore, both attributes and properties of contents and nodes can be incorporated to strengthen the scope of the scheme [23].

ACKNOWLEDGMENT

The authors would like to thank the Editor and reviewers for their helpful comments and suggestions.

REFERENCES

- [1] D. Evans, “The Internet of Things how the next evolution of the Internet is changing everything (April 2011),” Cisco Internet Business Solutions Group, San Jose, CA, USA, White Paper, 2012.
- [2] G. N. Cristina, G. V. Gheorghita, and U. Ioan, “Gradual development of an IoT architecture for real-world things,” in *Proc. IEEE Eur. Model. Symp. (EMS)*, Madrid, Spain, 2015, pp. 344–349.
- [3] *Cisco Visual Networking Index Predicts Near-Tripling of IP Traffic by 2020*, Cisco, San Jose, CA, USA, 2017. [Online]. Available: <https://newsroom.cisco.com/press-release-content?type=press-release&articleId=1771211>
- [4] W. Shang, Y. Yu, R. Droms, and L. Zhang, “Challenges in IoT networking via TCP/IP architecture,” NDN Project, Rep. NDN-0038, 2016.
- [5] G. Xylomenos *et al.*, “A survey of information-centric networking research,” *IEEE Commun. Surveys Tuts.*, vol. 16, no. 2, pp. 1024–1049, 2nd Quart., 2014.

- [6] *The CCNX Project*. Accessed: Jun. 15, 2016. [Online]. Available: <http://blogs.parc.com/ccnx/>
- [7] S. H. Ahmed, S. H. Bouk, and D. Kim, *Content-Centric Networks: An Overview, Applications and Research Challenges*. Singapore: Springer, 2016.
- [8] M. Amadeo *et al.*, “Information-centric networking for the Internet of Things: Challenges and opportunities,” *IEEE Netw.*, vol. 30, no. 2, pp. 92–100, Mar./Apr. 2016.
- [9] Y. Zhang *et al.*, “ICN based architecture for iot—Requirements and challenges draft-zhang-iot-icn-challenges-02,” Internet-Draft, ICN Res. Group, 2016. [Online]. Available: <https://tools.ietf.org/html/draft-zhang-iot-icn-challenges-02#page-12>
- [10] M. Amadeo, C. Campolo, A. Iera, and A. Molinaro, “Information centric networking in IoT scenarios: The case of a smart home,” in *Proc. IEEE Int. Conf. Commun. (ICC)*, London, U.K., 2015, pp. 648–653.
- [11] S. H. Bouk, S. H. Ahmed, and D. Kim, “Hierarchical and hash based naming with compact trie name management scheme for vehicular content centric networks,” *Comput. Commun.*, vol. 71, pp. 73–83, Nov. 2015.
- [12] W. Shang *et al.*, “Named data networking of things,” in *Proc. IEEE 1st Int. Conf. Internet Things Design Implement. (IoTDI)*, Berlin, Germany, 2016, pp. 117–128.
- [13] W. Shang, Q. Ding, A. Marianantoni, J. Burke, and L. Zhang, “Securing building management systems using named data networking,” *IEEE Netw.*, vol. 28, no. 3, pp. 50–56, May/June 2014.
- [14] S. H. Bouk, S. H. Ahmed, and D. Kim, “NDN goes deep: Foreseeing the underwater named data networks,” in *Proc. Symp. Appl. Comput.*, 2017, pp. 642–646.
- [15] M. A. M. Hail, M. Amadeo, A. Molinaro, and S. Fischer, “On the performance of caching and forwarding in information-centric networking for the IoT,” in *Proc. Int. Conf. Wired/Wireless Internet Commun.*, Marrakesh, Morocco, 2015, pp. 313–326.
- [16] E. Baccelli, C. Mehlis, O. Hahm, T. C. Schmidt, and M. Wählisch, “Information centric networking in the IoT: Experiments with NDN in the wild,” in *Proc. 1st Int. Conf. Inf. Centric Netw.*, Paris, France, 2014, pp. 77–86.
- [17] S. Li, Y. Zhang, D. Raychaudhuri, and R. Ravindran, “A comparative study of mobilityfirst and NDN based ICN-IoT architectures,” in *Proc. 10th Int. Conf. Heterogeneous Netw. Qual. Rel. Security Robustness (QShine)*, Rhodes, Greece, 2014, pp. 158–163.
- [18] M. Meisel, V. Pappas, and L. Zhang, “Ad hoc networking via named data,” in *Proc. 5th ACM Int. Workshop Mobility Evol. Internet Archit.*, Chicago, IL, USA, 2010, pp. 3–8.
- [19] G. Fowler, L. C. Noll, K.-P. Vo, and D. Eastlake, “The FNV non-cryptographic hash algorithm,” IETF-draft, 2011.
- [20] (2016). *Fowler Noll Vo Hash Function*. [Online]. Available: <http://will.thimbleby.net/algorithms/doku.php?id=fowler-noll-vo-hash-function>
- [21] B. Saadallah, A. Lahmadi, and O. Festor, “CCNX for contiki: Implementation details,” Ph.D. dissertation, INRIA, Rocquencourt, France, 2012.
- [22] H. Lamaazi, N. Benamar, M. I. Imaduddin, and A. J. Jara, “Performance assessment of the routing protocol for low power and lossy networks,” in *Proc. Int. Conf. Wireless Netw. Mobile Commun. (WINCOM)*, Marrakech, Morocco, 2015, pp. 1–8.
- [23] S. Arshad, M. A. Azam, S. H. Ahmed, and J. Loo, “Towards information-centric networking (ICN) naming for Internet of Things (IoT): The case of smart campus,” in *Proc. Int. Conf. Future Netw. Distrib. Syst. (ICFNDS)*, Cambridge, U.K., 2017, pp. 1–6. [Online]. Available: <http://doi.acm.org/10.1145/3102304.3102345>

Sobia Arshad (S’10–M’13) received the B.Sc. and M.Sc. degrees in computer engineering from the University of Engineering and Technology (UET), Taxila, Taxila, Pakistan, and the M.Sc. and Ph.D. degrees from UET, in 2011 and 2014, respectively.

She was with the Computer Science, Department, University of Lahore, Lahore, Pakistan, as an Assistant Professor and as a Visiting Lecturer with the Computer Science and Information Technology Department, University of Sargodha, Sargodha, Pakistan. She is currently a Ph.D. full-time Researcher with UET, Taxila. Since 2014, she has been with the Information Centric Networking-Based Internet of Things. Her current research interests include wireless sensor networks, Internet of Things, smart campus, future Internet, and information centric networking.

Dr. Arshad was the recipient of a Ph.D. full-time Scholarship.



Babar Shahzaad received the B.S. and M.S. degrees in computer engineering from the University of Engineering and Technology, Taxila, Taxila, Pakistan, in 2014 and 2016, respectively.

He is a Lecturer with the Department of Computer Science, University of Management and Technology, Sialkot, Pakistan. His current research interests include information-centric networking/named data networking applications for the Internet of Things (IoT), intelligent device-to-device communication, and security and privacy in the IoT.



Muhammad Awais Azam received the B.Sc. degree in computer engineering from the University of Engineering and Technology (UET), Taxila, Taxila, Pakistan, in 2006, the M.Sc. degree (with distinction) in wireless networks from Queen Mary University, London, U.K., in 2008, and the Ph.D. degree in pervasive and ubiquitous computing from the Engineering and Information Sciences Department, Middlesex University, London, U.K., in 2012.

From 2006 to 2007, he was a Lecturer with UET, Taxila. From 2012 to 2013, he was a Head of Academics with Cromwell College of Information Technology and Management, London, U.K. From 2013, he has been an Assistant Professor with the Department of Computer Engineering, UET, Taxila. He leads a research team of M.S. and Ph.D. students in the area of pervasive and ubiquitous computing. His current research interest includes network architecture, Internet of Things, network security, embedded systems, ambient intelligence, wireless communications, opportunistic networks, and recommender systems.

Dr. Azam was a recipient of a Gold Medal in 2006 for the B.Sc. degree.



Jonathan Loo received the M.Sc. degree (with distinction) in electronics and Ph.D. degree in electronics and communications from the University of Hertfordshire, Hertfordshire, U.K., in 1998 and 2003, respectively.

From 2003 to 2010, he was a Lecturer of multimedia communications with the School of Engineering and Design, Brunel University, Uxbridge, U.K., and from 2010 and 2017, he was an Associate Professor of communication networks with the School of Science and Technology, Middlesex University, London, U.K. From 2017, he has been a Chair Professor of computing and communication engineering with the School of Computing and Engineering, University of West London, London. He has successfully graduated 18 Ph.D. students as their Principal Supervisor and has co-authored over 240 journal and conference papers in the aforementioned specialized areas. His current research interests include information centric networking, cloud computing, wireless/mobile networks and protocols, network security, wireless communications, IoT/cyber-physical systems, and embedded systems.

Dr. Loo has been an Associate Editor for the *International Journal of Communication Systems* (Wiley) since 2011. He was the Lead Editor of *Mobile Ad Hoc Networks: Current Status and Future Trends* (CRC Press, 2011).



Syed Hassan Ahmed (S'13–M'17) received the B.S. degree in computer science from the Kohat University of Science and Technology, Kohat, Pakistan, and the master's combined Ph.D. degree from the School of Computer Science and Engineering (SCSE), Kyungpook National University (KNU), Daegu, South Korea.

In 2015, he was also a Visiting Researcher with the Georgia Institute of Technology, Atlanta, GA, USA. He authored/co-authored over 100 international publications including journal articles, conference proceedings, book chapters, and 2 books. He is currently a Post-Doctoral Fellow with the Department of Electrical and Computer Engineering, University of Central Florida, Orlando, FL, USA. His current research interests include sensor and ad hoc networks, cyber-physical systems, vehicular communications, and future Internet.

Dr. Ahmed was a recipient of the Research Contribution Award by SCSE of KNU from 2014 to 2016 and the Qualcomm Innovation Award of KNU for his work on robust content retrieval in future vehicular networks in 2016.



Saleem Aslam received the B.S. degree from the University of Engineering and Technology, Taxila, Taxila, Pakistan, in 2006, the M.S. degree from the National University of Sciences and Technology, Islamabad, Pakistan, in 2008, and the Ph.D. degree from Sejong University, Seoul, South Korea, in 2013.

From 2007 to 2011, he was a Lecturer with the National University of Computer and Emerging Sciences, Islamabad. He was a Research Assistant with the Network Research Laboratory, Sejong University from 2011 to 2013. From 2014 to 2015, he was a Post-Doctoral Fellow with the Wireless Communications and Signal Processing Laboratory, Queens University, Kingston, ON, Canada. He was a Visiting Research Fellow with the Mobile Networks Laboratory, Sogang University, Seoul, South Korea, from 2016 to 2017. Since 2015, he has been with Bahria University, Islamabad. He was the Head of Electrical Engineering Department from 2016 to 2017 and currently is an Assistant Professor with the Electrical Engineering Department. His current research interests include spectral and energy efficient solutions for next-generation cellular, sensor, Internet of Things, and smart building networks.