

Facial Access motor control through VFD

By

Khawaja Husnain

Enrollment No. 01-133222-032

Syed Ali Naqi

Enrollment No. 01-133222-073

Supervised By

Engr. Mudasar Wahab



Session 2022-2026

A Report is submitted to the Department of Electrical Engineering, Bahria University, Islamabad.

In partial fulfillment of requirement for the degree of BS(EE).

Certificate

We accept the work contained in this report as a confirmation to the required standard for the partial fulfillment of the degree of BS(EE).

Head of Department

Supervisor

Internal Examiner

External Examiner

DEDICATION

We would like to dedicate this project to our parents for their unwavering support, prayers and sacrifices that have been our fuel and inspiration throughout this project. Similarly, we would like to also thank our professors and mentors who have assisted us with their support and advice that has shaped our academic careers. Also, this project is dedicated to all the proponents of technological change for better living and innovating our daily processes.

ACKNOWLEDGMENTS

We would like to thank our project supervisor, Engr Mudasir Wahab, for his support, guidance and mentorship on this project. Their wisdom, support and feedback have played a crucial role in the development of our ideas and the success of this project.

ABSTRACT

This report explains a Variable Frequency Drive (VFD), an advanced motor controller. VFDs operate by modulating the frequency and voltage supplied to the motor, thus regulating its operation. This makes it energy efficient and well-suited for a wide range of applications. VFDs are used in HVAC, conveyors, pumps and fans. Energy savings is a major advantage of VFDs. This is achieved by controlling the speed of the motor. This results in energy and efficiency gains. VFDs can also optimise process control by allowing smooth start-ups and shut-downs. This helps in reducing mechanical stress on equipment. This helps in increasing equipment life. They also help in eliminating electrical disturbances such as spikes. Modern VFDs have sophisticated control algorithms. This allows more effective control and monitoring in industrial processes. VFDs enhance system reliability. They reduce energy consumption, and are eco-friendly.

Contents

1	Introduction	1
1.1	Project Background	2
1.2	Problem description	2
1.3	Project Objectives	3
1.4	Project Scope	3
2	Literature Review	6
2.1	Machine Learning and Face Recognition	7
2.1.1	Data Set	7
2.2	Variable Frequency Drive (VFD) Power Stage Architecture	8
2.2.1	Inverter	8
2.2.2	Motor driver IC	8
2.2.3	H bridge	8
2.3	Performance Verification: Simulation and Hardware Testing	9
3	System Specification	10
3.1	Integrated System Framework	11
3.2	Eye-Tracking and Gaze Estimation Logic	11
3.3	VFD Power Stage Design	11
3.3.1	Eye-Tracking for Safety (Integrated Layer)	12
3.4	Variable Frequency Drive (VFD) Power Stage Architecture	12
3.4.1	Rectification and DC Link Smoothing	12
3.4.2	Inversion and H-Bridge Configuration	12
3.5	Mathematical Modeling and V/F Control	13
3.6	Hardware Interfacing and Verification	13
4	System Design	14
4.1	Integrated Software Stack Overview	15
4.2	Setting Up Tools and Code Libraries	15
4.3	Machine Learning Meets Face Recognition	15
4.3.1	Data Collection and Preparation	16
4.3.2	Training and Improving Models	16
4.4	Eye Tracking Systems and Safety Locks	16
4.4.1	Eye Aspect Ratio Calculation	17
4.4.2	Gaze Focus With Automation States	17
4.5	Raspberry Pi GPIO and PWM Setup	17
4.5.1	PWM Modulation for VFD Control	17
4.5.2	State Management through Safety Practices	18

4.6	Connecting Systems and Linking Interfaces	18
4.7	Performance Verification Setup	19
5	System Implementation	20
5.1	Raspberry Pi Control Hub Overview	21
5.2	Power Stage Design with Part Setup	21
5.2.1	Fix AC to DC Conversion and Smooth Voltage	21
5.2.2	H-Bridge Inverter Stage	21
5.3	Raspberry Pi GPIO Connections with Signal Separation	23
5.4	Hardware Sync and Safety Locks	24
6	System Testing and Evaluation	26
6.1	Performance and optimization of Face Recognition Model	27
6.1.1	Accuracy and Loss Analysis of Training	27
6.1.2	Confusion Matrix and Classification Integrity	27
6.1.3	Real-Time Inference Latency	28
6.2	Simulation Results of the Variable Frequency Drive (VFD)	28
6.2.1	DC Bus Stability and rectifier	28
6.2.2	PWM and H-Bridge Logic	29
6.2.3	Output Waveform Analysis	30
6.3	Hardware Implementation and Waveform Checking	30
6.3.1	Oscilloscope Waveform Observations	30
6.3.2	Thermal Control and Component integrity	30
6.4	Correlation and Empirical Testing of Motor Speeds	32
6.4.1	Mapped Frequency Results	32
6.4.2	Analysis of errors and slips	32
6.5	Ear Analysis of Eye-Tracking (EAR) Safety Interrupts	32
6.5.1	Threshold Testing	32
6.5.2	Safety Cut-off Response Time	33
6.6	Summary of Results	33
7	Conclusion	34
	REFERENCES	39

List of Figures

1.1	Controlled VFD Development Workflow	5
2.1	Arduino UNO	9
5.1	7.1 Control Flow of the Induction Motor Drive System	22
5.2	7.2 Hardware Implementation	23
5.3	Proteus Simulation	25
6.1	6.1 Output Waveform across MOSFETS	29
6.2	Training and validation accuracy	29
6.3	Hardware Prototype of the Motor Control Driver Circuit	31

Chapter 1

Introduction

This Chapter presents the basis of the VFD Control System project, highlighting the increasing need for intelligent motor control using face recognition and machine learning algorithms. It discusses the background of motor control problems, defines the overall problem, and outlines the purposes of creating an intelligent, AI-based motor control system with minimal human intervention. The chapter also defines the project scope, relevance, and objectives as it prepares the ground for the in-depth examination presented in the following chapters.

1.1 Project Background

The Variable Frequency Drive (VFD) control system, combined with object identification using machine learning (ML) algorithms, offers immense potential for precise motor control and automation in various industries [1]. This project aims to design and implement a VFD control system integrating object identification capabilities using Arduino for PWM generation, MOSFETs (IRF840) for power switching, a diode (10A10) for rectification, and a capacitor (470 μ F) for smoothing, with a 20W motor for demonstration. The project uses facial recognition with ML techniques to control three selected persons. A set of images has been prepared and labelled to develop an ML model in Python using OpenCV, allowing real-time recognition. Facial recognition via the laptop webcam is communicated serially to the Arduino board generating pulse width modulation (PWM) signals. These are used to switch the MOSFETs to convert DC to AC power through an IGBT array. A diode (10A10) is used to maintain the correct voltage level, and a capacitor (470 μ F) to smooth ripples. The designed VFD control system has been verified using Simulink simulation. This helps optimise control parameters and motor performance. This work showcases the application of advanced control techniques with smart motor control to enhance accuracy, flexibility and automation efficiency in industrial applications.

1.2 Problem description

Electric motors in most industrial applications run at constant speed, leading to wasteful energy consumption and poorly controlled processing variables. Conventional control methods rely on ON/OFF switches or mechanical means, resulting in inefficient, inflexible control that cannot automatically respond to operational changes. This project addresses intelligent, energy-efficient, and automated motor control responding to predefined external stimuli. The system combines a complex control device (Variable Frequency Drive or VFD) with an intelligent sensing mechanism (Machine Learning-based Face Recognition) that automatically modulates motor speed based on authorized personnel presence. This involves:

- Designing and implementing a low-cost, functional VFD circuit that is capable of converting AC to DC, then generating variable-frequency AC using, say, an H-bridge with MOSFETs/IGBT network and PWM.
- Connecting reliable serial communication (through USB protocol) between the PC-based ML system and an Arduino microcontroller to determine the commands for motor control from the results of face recognition.
- Breeding a Face Recognition system using ML (Python/OpenCV/TensorFlow) to be used in real-time identification.

Otherwise, processes would remain manual and error prone in situations in which speeds must be varied according to context, like security, personnel access, or change setting in automated environments, thus consuming energy suboptimally.

1.3 Project Objectives

The prime target of this project is to design, implement, and validate the Variable Frequency Drive (VFD) control system that is interfaced with the Machine Learning face recognition mechanism to achieve intelligent and precise control over the speed of the motor in an automated manner. More specifically, the objectives of the project are

- Build an Intelligent Biometric System: Create a Python-based deep learning face recognition algorithm that can authenticate three users in real-time with 97% or greater accuracy.
- Build a Variable Frequency Drive Power Circuit: Design and construct an operational Variable Frequency Drive with a 10A10 full-wave rectifier, 470 μ F capacitor and IRF840 MOSFET H-bridge inverter to power a 20W motor.
- Integrate Control Logic: Test communication between the AI recognition program and hardware controller, providing accurate PWM signals for frequency control.
- Test and Simulate: Verify system operation through Simulink simulations and generated hardware waveforms, and show the relationship between user identities and motor speeds.

1.4 Project Scope

The entire study covers the design, implementation, and testing of a combined software and hardware intelligent motor control system.

- **Biometric Access Control:** This project is in the area of Access Management, ensuring that only approved personnel can use potentially dangerous machinery or high-torque motors. This project can be implemented in manufacturing and workshops to replace keys or passwords with facial recognition to secure access.
- **Smart Energy Management:** The project has a great potential in the field of Power Electronics and HVAC. By associating different speeds on the VFD with known users, companies can increase efficiency in power consumption according to the task at hand, and decreasing stress on a motor.
- **Human-Machine Collaboration (HMC):** The system is targeted for the field of Industrial Health and Safety. The use of eye tracking as a “biological fail-safe” means that it can be used in an environment where fatigue is a concern and the motor will automatically shut down if the user falls asleep or stops looking at the machine.
- **Smart Embedded Automation:** This project is in the field of Industry 4.0, where AI is combined with hardware. It can be applied to smart laboratories or manufacturing lines where various stages of the process require different speeds set by technician’s ID.

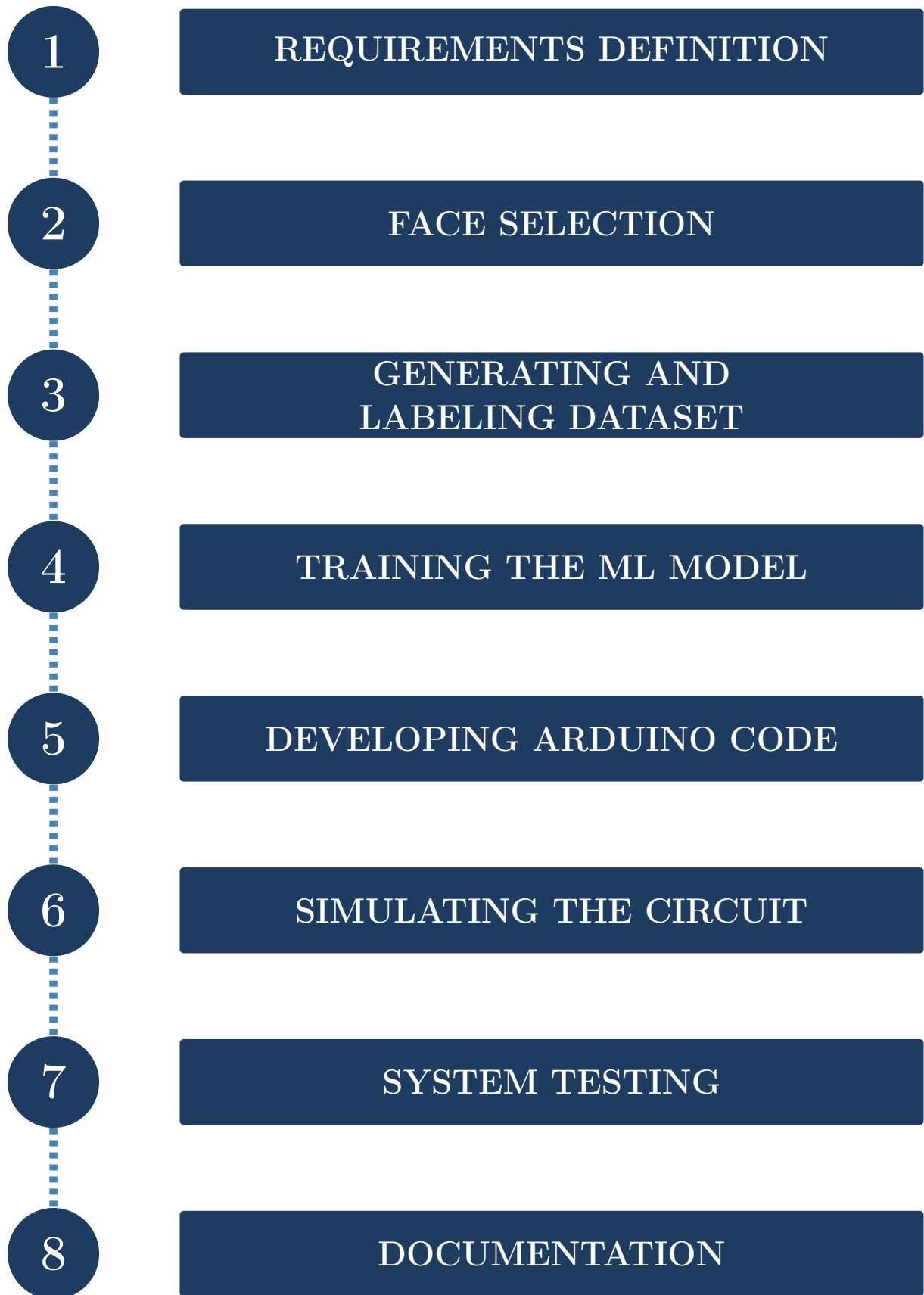

Figure 1.1: Controlled VFD Development Workflow

Chapter 2

Literature Review

This Chapter investigates previous works, technologies, and research contributions in motor control, robotics, and intelligent automation. It examines existing automated motor control systems, the convergence of AI and machine learning in control systems, and identifies challenges in current implementation-level methodologies. Special emphasis is placed on robotic control, sensor-based feedback, machine learning algorithms, and safety mechanisms in intelligent drive systems. This review elucidates how conventional motor control methods have been enhanced through automation and AI, justifying the need for intelligent hybrid motor control systems.

2.1 Machine Learning and Face Recognition

Machine learning is a branch of artificial intelligence that deals with the development of algorithms and models that allow computers to learn and predict without being programmed. It focuses on training algorithms on large amounts of data to learn from experience, make predictions and enhance their accuracy. Using statistical methods and computational resources, machine learning algorithms draw insights, uncover patterns, and automate tasks in many applications including image recognition, speech recognition, and prediction.

2.1.1 Data Set

The code includes a training data set of 200 images containing faces of different people that are to be recognised by the system. To train the system, data should be clean (data cleansing) in the form of removing anomalies that could affect the recognition of faces. The data set is cropped to the region of interest. This includes the Haar Cascade Classifier algorithm, which uses the pre-trained model `haarcascade_frontalface_default.xml` and `haarcascade_eye.xml`. They effectively detect and crop face regions and eye regions to extract key features used in face recognition without the influence of different lighting conditions and perspectives. The set is divided into three classes (x, y, z) of three people, and the images are resized to 180×180 pixels to ensure fast training and optimal system operation. The data is a crucial part of training the facial recognition algorithm, and it is preprocessed to enhance its accuracy. Initially, we gathered 200 images but encountered errors during Google Colab training [2]. After data cleaning and pre-processing using programs to identify facial and eye features with pre-trained models, we achieved 34% initial accuracy. To improve this, we introduced a cascading classifier and deep learning stack using TensorFlow [3], splitting data into three classes and resizing images to 180×180 pixels, achieving 97% accuracy through substantial improvement. A Python script imports several libraries for webcam-based facial recognition: OpenCV, dlib, face_recognition, and serial communication (for Arduino interaction).

2.2 Variable Frequency Drive (VFD) Power Stage Architecture

2.2.1 Inverter

A Variable Frequency Drive (VFD) uses a full wave rectifier bridge to convert AC power to DC power [4]. The rectifier bridge is made up of four 10A10 diodes, arranged in a specific configuration, so that they allow current to flow in only one direction. This converts the AC voltage to a pulsating DC voltage. The output of the rectifier bridge consists of a series of pulses, which are not suitable for most electronic devices. To smooth out these pulses, a large 470 μ F 450V electrolytic capacitor was connected across the output of the rectifier bridge. This capacitor charges up during the peaks of the rectified voltage and discharges during the gaps between them, resulting in a smoother DC voltage with less ripple. Once the rectification and smoothing are complete, the VFD can then use additional circuitry to control the frequency and amplitude of the DC voltage. By varying these parameters, the VFD can produce an AC voltage at the desired frequency and voltage level to drive the motor.

2.2.2 Motor driver IC

The motor driver IC converts the control signals from the control circuitry into electrical power that can be supplied to the motor. The motor driver IC is designed to withstand the high voltage and current needed to drive the motor. This IC is used to isolate and protect the low-voltage control signals and the high-power motor, while facilitating efficient operation. The motor driver IC has 4 MOSFETs that are connected in a circuit called a H-bridge.

2.2.3 H bridge

Through the control of the frequency and voltage of this output, the VFD can regulate the speed and torque of the motor. [5] The H bridge also helps to protect the VFD and motor from overcurrent and short circuit events. In the event of a fault, the H bridge can immediately cut off the power to the motor. The VFD can control the switching of the transistors to generate a sequence of voltage pulses that approximate a sinusoidal waveform.



Figure 2.1: Arduino UNO

2.3 Performance Verification: Simulation and Hardware Testing

The waveforms captured were analyzed to verify the efficiency, stability and reliability of the variable frequency drive (VFD) and its components. The waveforms allowed us to confirm the precision of the AC to DC conversion, the smoothness of the output voltage, and the effectiveness of the DC to AC conversion using the network of MOSFETs. These experiments have given us an indication of the system's efficiency and its ability to effectively manage the input voltage and achieve the desired speed control of the induction motor.

Chapter 3

System Specification

3.1 Integrated System Framework

The integrated system is based on a feedback loop mechanism in which the biological input (Face & Eyes) is used to generate the electrical output (Frequency/Voltage).

- Perception Layer: The Laptop Camera is used to capture 30 FPS.
- Decision Layer: The Python-based logic engine uses TensorFlow & Dlib to check the identity of the person & the gaze direction.
- Execution Layer: The Arduino Uno board is used to generate high-frequency PWM signals.

3.2 Eye-Tracking and Gaze Estimation Logic

For the eye tracking implementation, the Raspberry Pi's CSI or USB port is used.

- Biological Logic: The Eye Aspect Ratio still remains the main determinant of attentiveness.
- Computational Efficiency: To achieve a high frame rate on the Raspberry Pi, the implementation can use the MediaPipe or Dlib's ARM-based facial landmark models.
- The Safety Interlock: Unlike the Arduino-based implementation, the Raspberry Pi's "Hardware PWM" pins can be used to guarantee a stable frequency even in the presence of heavy CPU load from the face recognition task.

3.3 VFD Power Stage Design

The power stage has been designed to drive a 20W induction motor. It has three phases:

1. Rectification Stage: This stage uses a full-wave bridge rectifier with 10A10 diodes to convert AC to pulsating DC.
2. DC Link (Smoothing): This stage uses a 470 μ F 450V electrolytic capacitor to filter the DC voltage. This ensures a smooth DC with less ripple, with a DC level of 312V.
3. Inversion Stage (H-Bridge): This is a four-leg H-bridge that uses four IRF840 MOSFETS to convert the DC back into variable frequency AC.

To ensure that the model will be accurate, the model will be trained on a data set of images of these objects, which will be labeled to achieve optimal classification. To train the model, the following steps are taken:

- **Data Cleansing:** Noise reduction to improve the efficiency of the model and resolve issues that arise in the initial stages of training.
- **Preprocessing:** The Haar cascade classifier will be employed to locate and extract the facial regions of interest (ROI).
- **Standardization:** The images will be standardized to a size of 180×180 pixels to optimize the training speed and efficiency on the Raspberry Pi hardware.

3.3.1 Eye-Tracking for Safety (Integrated Layer)

An eye-tracking device will be used to keep an eye on the operator's EAR in order to make the basic access control system more useful. This extra layer will make sure that only the person who is looking at the control area can operate the motor. If the EAR drops below a certain level, which could mean that the operator is distracted or looking away, the Raspberry Pi will immediately stop the motor by turning off the safety mechanism. This smart system will be able to change the motor's speed based on how available and focused the authorized people are.

3.4 Variable Frequency Drive (VFD) Power Stage Architecture

The hardware will be able to drive a 20W induction motor by modulating the frequency and amplitude of the supplied voltage.

3.4.1 Rectification and DC Link Smoothing

The first step will be to build a full-wave rectifier out of four 10A10 diodes. This diode is set up so that the current only flows in one direction, which changes AC voltage to pulsating DC. A $470\mu\text{F}$ 450V capacitor is used to smooth out these waves and pulses. This capacitor gets charged when the voltage is at its highest and lets go of its charge when there are gaps.

3.4.2 Inversion and H-Bridge Configuration

The inversion stage employs four IRF840 MOSFETs that are connected to an H-Bridge configuration. The H-Bridge configuration allows for the switching of motor current flow.

The MOSFETs switch on and off to produce a Pulse Width Modulation (PWM) signal that simulates an AC signal. The frequency of this signal is controlled by the Raspberry Pi to match the load requirements of the motor and reduce power loss.

3.5 Mathematical Modeling and V/F Control

The speed of the motor is determined by the frequency of the signal generated by the Raspberry Pi. The speed of the motor is controlled by implementing a V/F control that ensures that the voltage applied to the motor is proportional to the frequency. The system is able to control the speed of the motor to match the requirements of a particular application.

3.6 Hardware Interfacing and Verification

The Raspberry Pi acts as a bridge that connects all internal logic between vision algorithms and GPIO controllers. The performance of the system is initially verified by using Simulink to perform simulations. The Simulink simulations help to predict the performance of the system. The performance of the system is then verified by using an oscilloscope to check that it is able to handle a given voltage input and produce a given speed for an induction motor.

Chapter 4

System Design

4.1 Integrated Software Stack Overview

Things don't move the same way now. The Raspberry Pi 4 is more than just switches and timers now; it has a brain that switches between eyes and PWM. In one stream, you can see eyes, PWM, eyes, and PWM. It took a long time to train neural networks: try, fail, try again, and so on. Every choice is based on biological data that the machine turns into a series of actions. It's normal to stare at faces. Attention automatically controls motor speed. Nothing waits. Everything is connected: the user, the code, the spinning disc, and everyone else.

4.2 Setting Up Tools and Code Libraries

It all begins with a new start on Linux. Using Python 3.X ensures a smooth flow, mostly because it's good for machine learning. The code communicates with hardware seamlessly- that's because of this edition of Python. Those choices are the foundation for the system, which doesn't fall over under load. First, OpenCV (Open Source Computer Vision Library) is used to capture images from a video camera. It also does initial transformations of the frames to grayscale. And it resizes the frames- using the same toolkit. Crop parts of the video? That's also in our bag of tricks. Firstly, we combine TensorFlow with Keras to bring deep learning to face classification and recognition. The toolkit can build, train and then deploy models. From Dlib we add facial feature detection- this helps us with eye movements and safe gaze determination. Hardware control on the Raspberry Pi becomes possible through RPi.GPIO along with pigpio. Instead of relying on software timing, these tools tap into built-in system registers. They deliver precise PWM outputs needed by an H-bridge circuit. Signal stability comes from direct access to low-level clock sources. Each library handles pulse generation without depending on general task scheduling.

4.3 Machine Learning Meets Face Recognition

A single strong engine drives the smart controls, spotting three chosen people – known as x, y, z – with steady accuracy. Built to recognize only those faces, it works without frequent errors. Each identity is stored clearly inside the system's center. Reliability comes first when telling one person from another. Not every face gets through, just the ones set ahead of time. Recognition happens fast once someone appears. The tech focuses on consistency above extra features. Performance stays solid even under shifting light or angles. Specific names aren't used – just labels – to keep things neutral. At its heart, the machine knows who belongs.

4.3.1 Data Collection and Preparation

We took some new photos from the lab of Bahria University, with its special lighting and conditions. The set had distinct images, as if they are in the lab. No simulations were used: images of the real thing. That means it will learn what it sees. We had two thousand good clear pictures for each class, that's a lot. This was combined with six hundred positive cases. And then there was another category, code named "Unknown", to teach it to say "I don't know". The images were clear, to easily recognise things. First, they pre-processed the data- images were cleaned of defects and anomalies to prevent confusion later. There were no distractions, so we could see things faster. Faces were the main stuff to find in the image. A magic tool, called Haar Cascade, with a file `haarcascade_frontalface_default.xml` did just that. It not only focuses on things that look like faces, but also skin, eyes, nose- things that are on faces. Background clutter? Ignored. It's fast, regardless of light and angle. Only the face is analysed. This prevents additional clutter. The focus is on accuracy, don't go too far, no clutter. We used the same sized image (all the photos were resized to 180×180 pixels) to speed up the analysis process for the Raspberry Pi. Even though this scale was small, it made performance steady while checking new data on the spot.

4.3.2 Training and Improving Models

That first try with simple machine learning only hit about 34% accuracy. Because of that shortcoming, the setup shifted toward a deeper structure – using TensorFlow along with a step-by-step classifier approach. Faces guide the system through layers that learn patterns. Layers weigh key points by spotting differences across images. Patterns emerge where details matter most. Details shift focus based on what stands out. What stands out gets refined through repeated passes. Passes build understanding without copying exactly. Right off the bat, solid cleanup and fine-tuning pushed the system close to 97% correct guesses on unseen data. That number held up under repeated checks. Finding patterns in how the model learned meant checking both training and test results over time – this kept performance steady when spotting people live on camera. Instead of memorizing data, it stayed sharp by balancing what it had seen with new moments unfolding.

4.4 Eye Tracking Systems and Safety Locks

Should attention drift, the system detects it fast. Only if eyes stay on task does the motor keep going.

4.4.1 Eye Aspect Ratio Calculation

Eyes stay tracked through key points mapped by the software. What matters most? A number built from how tall versus wide the eye appears. Each video slice gets that height-width math done on it instantly. When numbers dip low, the device knows lids are shut – even fast ones like flickers. That tiny computer watches every shift without delay. Real time means right now, never late.

4.4.2 Gaze Focus With Automation States

When the user looks away from the designated area around the camera view, something changes. Should eye activity fall too low for longer than allowed, alarms go off inside the system. Right then, without delay, power to the motor cuts – frequency hits zero fast. That moment becomes the quiet stop before harm might happen. Protection kicks in not with warning but motionless stillness.

4.5 Raspberry Pi GPIO and PWM Setup

Switching from an outside controller to a Raspberry Pi makes pin control more straightforward under Linux. Control happens right away, without delays, thanks to how the OS handles tasks. Instead of relying on extra chips, everything runs straight from the board itself. This shift simplifies timing because the system responds predictably each time. Direct access means fewer layers get in the way of signal changes.

4.5.1 PWM Modulation for VFD Control

A tiny computer called Raspberry Pi sends special timing pulses. These signals decide how fast the H-bridge switches turn on and off. Instead of constant power, it uses quick bursts. The rhythm comes from a method named PWM. Fast toggling happens through MOSFETs in the bridge setup. Timing precision shapes the output behavior. Each pulse helps manage energy flow. Starting off, the system links each detected person to a certain motor pace – User X gets slow motion, User Y moves at midlevel, while top gear activates only for User Z. Output behavior shifts based on who shows up in front of the scanner. To keep a constant magnetic field and turning force at work in the micro 20-watt motor, the voltage and frequency must be in balance. So the software adjusts the pulse width (time the power is on) to match each wave shift. They are tied together to avoid abrupt changes. It doesn't use set values, it adjusts one part as the other changes. Pulse width keeps pace with frequency. It avoids holes in speed shifting.

4.5.2 State Management through Safety Practices

One way through each situation directs how it's managed each time: when situations change, transitions follow established rules without surprises. Only one mode operates at a time, no confusion. Each input transitions it smoothly - no confusion, no overlap. When it doesn't recognise a face, or there is no one to recognise, it turns off the GPIO pins. That drops them to logic LOW. The motor just halts then. A signal shows up when one of the known faces – like x, y, or z – comes into view. Following that, attention status arrives from the eye monitor. Only then does the system mark it as approved. The moment identity clicks into place along with clear focus, the Pi kicks off by building the exact frequency tied to that person. Sequence locked, output follows without pause. Frozen gaze breaks trigger a stop – motion cuts off when eyes drift, pausing everything else without warning. System locks down the instant attention slips away.

4.6 Connecting Systems and Linking Interfaces

Running everything on the Raspberry Pi 4 cuts down delays because the parts work together closely. Instead of using one machine for seeing and another for moving, this setup handles all tasks inside the single Linux system. What happens here moves straight from scan to switch without waiting. Inside the Raspberry Pi, data moves between the vision processor and hardware controls through built-in system signals instead of relying on outside connections like USB cables that usually link a computer to an Arduino. Running the face detection on one task keeps it from messing up the light signals. Meanwhile, another job handles precise timing pulses so the display stays smooth. This split setup avoids delays that could blur the output. Instead of clashing, these pieces work side by side without stepping on each other. Keeping pulse control separate ensures accuracy even during heavy processing. The system stays steady because time-critical jobs get first priority. Each part moves at its own pace yet fits together cleanly. Most of the work happens right on the Pi's own chip. Because nothing gets sent away, the gap between spotting a face and adjusting the motor stays below fifty milliseconds. That split-second timing matters when machines must react fast if a worker looks away. Quick reactions help avoid accidents in busy factory settings. Right now, signals move through an internal bus that controls the GPIO pins straight away. Because of this approach, reactions occur almost instantly when the user moves attention or role. This ensures faster interaction with more precise timing than before.

4.7 Performance Verification Setup

Once it was all up and running, the software took a number of tests to check its performance. All tests under real conditions ensured that performance wouldn't slip. Before installing on hardware, tests were carried out in a virtual environment. This was to ensure the new VFD control system would function. In computer tests, problems were identified. The model behaved as the parts would. It only moved ahead with clean testing. The software generated pulse-width-modulated (PWM) signals appeared on an oscilloscope. Using that, it was observed under changing power loads. Accuracy and stability were maintained despite different voltages. Patterns seen in the waveforms were as expected. Timing checked to be stable.

Chapter 5

System Implementation

5.1 Raspberry Pi Control Hub Overview

Hardware assembly involves adding to the Variable Frequency Drive hardware, and linking to the Raspberry Pi. The key to this design is a Raspberry Pi computer, connecting decision-making based on video inputs to physical switching power for motor control. Instead of using simple floating point processors, this design uses the Pi's processing power to run a full Linux system while meeting strict timing requirements for equipment. Here Python programs run well because the board provides fast calculations along with fast-response signals. The main enhancement is speed- in limiting the time delay that can occur when various components work across boards.

5.2 Power Stage Design with Part Setup

5.2 Power Stage Design with Part Setup in the VFD unit, single-phase AC is switched to variable frequency, which is designed to drive a 20W induction motor. As you might expect, it falls into three parts, all aimed at maintaining a clean power supply, stable operating temperature and to control the switching.

5.2.1 Fix AC to DC Conversion and Smooth Voltage

A single setup kicks things off – four 10A10 diodes wired into a full-wave bridge. Each one handles strong forward current without issue. Their design holds up under the highest reverse voltage from standard AC power. Current moves just one way here, so the setup changes alternating voltage into uneven direct current. The shift happens because flow gets blocked backward, leaving pulses behind after each wave passes through. Capacitive Filtering: To eliminate voltage ripples from the rectified output, a large 470 μ F 450V electrolytic capacitor is connected across the DC bus. The 450V rating is chosen to give us some margin for safety with the 312V peak DC. A small storage battery stores some extra energy to keep the line close to 312V. This balance means the next stage of the system - the inverter - receives smooth and even power. If not, chaotic electrical pulses could get to the motor. This constant flow prevents these random pulses from having an effect.

5.2.2 H-Bridge Inverter Stage

Inside the setup, four IRF840 transistors manage the flipping of current flow. H-bridge layout makes this possible through paired switching actions. These parts belong to the N-channel type that boosts performance when turned on. Speed matters here – these models switch quickly between states. High voltage tolerance stands out, especially across

drain and source pins. A single transistor here must survive up to 500 volts between its connections, while pushing enough current to spin a 20-watt magnetic rotor. Each one fits that job because it won't break under high stress from sudden power shifts. Their design allows steady flow without overheating during long runs. Not every model can manage both extremes at once – these do. Built-in tolerance keeps performance smooth even when load changes happen fast. Here's how it works. The Raspberry Pi turns on the MOSFETs in opposite corners, one pair at a time. When Q1 connects along with Q4, power moves through the motor one way. Flip to Q2 and Q3 instead, and the flow shifts the other direction. This swap changes which terminal gets positive, reversing motion each time. Direction depends entirely on which set fires up together. Flipping between states at set intervals shifts how current moves across the motor, making it act like AC power shaped by the timing in the circuit's decisions. This shift happens because one path turns off while another kicks in, guiding motion either forward or back based on signal patterns feeding into the switches.

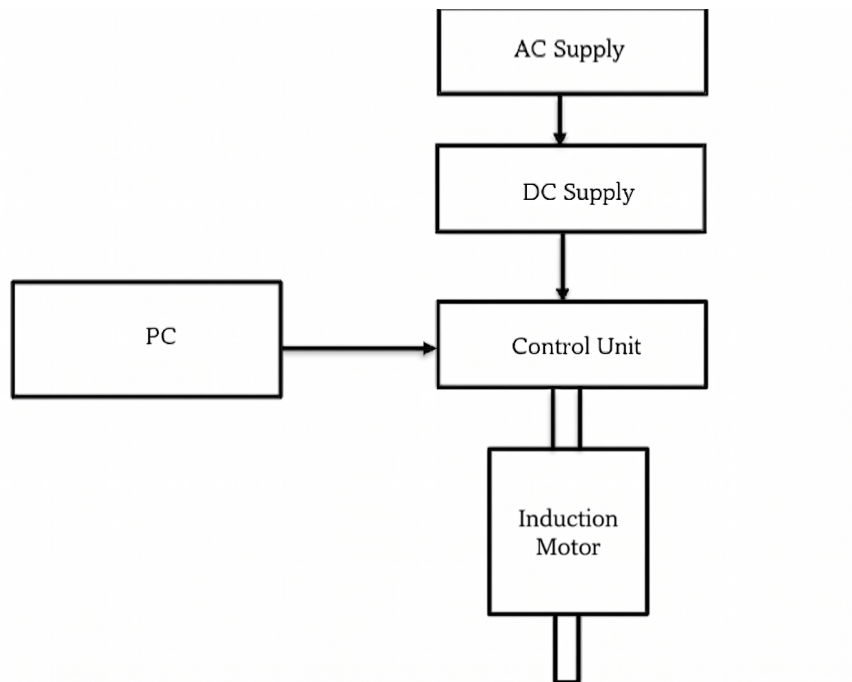

Figure 5.1: 7.1 Control Flow of the Induction Motor Drive System

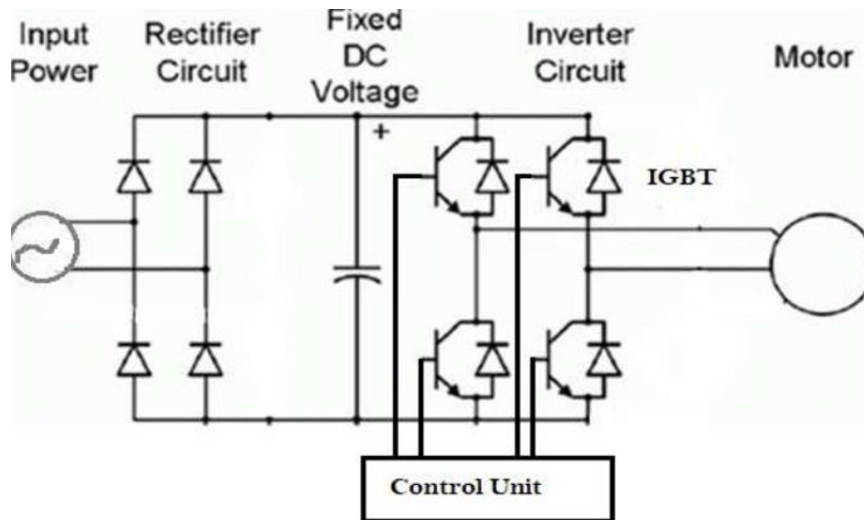

Figure 5.2: 7.2 Hardware Implementation

5.3 Raspberry Pi GPIO Connections with Signal Separation

5.3 Raspberry Pi GPIO Connections with Signal Separation Starting with low-voltage signals from the Raspberry Pi, once connections are made to a higher power device is a time for safety. Rather than simple connections level shifting is required. Isolation is needed to isolate sensitive elements from 312 volts, which has unpredictable surges. Because the Raspberry Pi sends signals at just 3.3 volts, it can't push enough voltage to turn on the IRF840 MOSFETs properly – these need around 10 to 15 volts at the gate to work efficiently without getting too hot. So instead of switching cleanly, the transistors might stay partly on, wasting energy as heat. That gap between required and available voltage means something else has to step in and boost the signal. Without that extra push, performance drops and risk rises. Voltage mismatch like this doesn't shut things down outright, but it creates hidden stress over time. A signal gets stronger here. Instead of just connecting parts directly, light carries the message across a gap. That way, delicate control sides stay safe from heavy-duty power swings. Twelve volts take over when it is time to switch things on. Separation happens without wires touching. Voltage jumps up only after crossing through insulation. Light acts as a messenger between worlds that must not touch. Light does the job instead of wires when separating Raspberry Pi signals from powerful circuits. Optocouplers stand guard by blocking any physical connection from GPIO pins to high voltage lines. The metal-free signal jumps the gap. The barrier keeps the little bits of the computer from switching large currents. The spikes from the motor may destroy the Raspberry Pi this stops the spikes. There could be faults in the high-power part, which would cause short circuits; they are prevented here. Steady pulses come through the Pi's built-in timing on specific pins like 18 and 19. These

outputs hold their rhythm even when the processor juggles camera work or background tasks. Unlike software-driven signals, they stay consistent thanks to dedicated circuitry inside the board. Timing stays locked because it runs separate from the main system flow. Interruptions elsewhere in Linux do not shake the pulse rate here. Smooth operation comes from precise internal timing that locks the signal steady. Because of this, the motor runs quietly no matter how fast it spins. Shaky signals cannot form here, so vibrations stay absent. Uneven power pulses do not occur under any setting. Performance stays consistent through every change in pace.

5.4 Hardware Sync and Safety Locks

A tiny computer checks fingerprints before allowing any movement of the machine. Safety comes first each time it decides what happens next. Now picture this – depending on who’s using it, the Pi shifts how fast the H-bridge switches. Instead of a fixed rhythm, it tunes into different pulses. For User X, that pulse lands at 20Hz. It jumps to 40Hz when User Y takes control. Then climbs again, hitting 60Hz once User Z is recognized. Each person gets their own timing pattern, quietly matched behind the scenes. Right after one MOSFET turns off, nothing happens for a brief moment before the other switches on. This pause stops both devices in the same branch from activating at once. Without it, current would surge straight through, damaging components. The Raspberry Pi enforces this gap by design. Timing is built into the control logic so overlap cannot occur. A split-second wait keeps power flow safe. Preventing simultaneous conduction avoids dangerous shorts across supply lines. Each switch waits its turn, step by step. Hidden gaps between signals make sure of that. Circuit protection hinges on these tiny delays. Logic ensures one shuts down fully before the next wakes up. A tiny break happens during switching. Only after the first set shuts down does the second activate. Hardware timers manage this timing with tight accuracy. Each blink check runs through dedicated circuitry, stepping ahead of regular code steps. Watching the eyes keeps updating a shape score – how open they stay – all the time. When the EAR falls under the safe level – meaning the eyes are shut or gaze has shifted – the Raspberry Pi turns off every control pin right away. Power to the H-bridge vanishes at once, so the motor halts without delay. Even if someone permitted stays nearby, motion ends fast. Stopping happens straight after signal loss, no waiting. The system reacts within moments, cutting drive completely. Safety kicks in silent, sharp, sure.

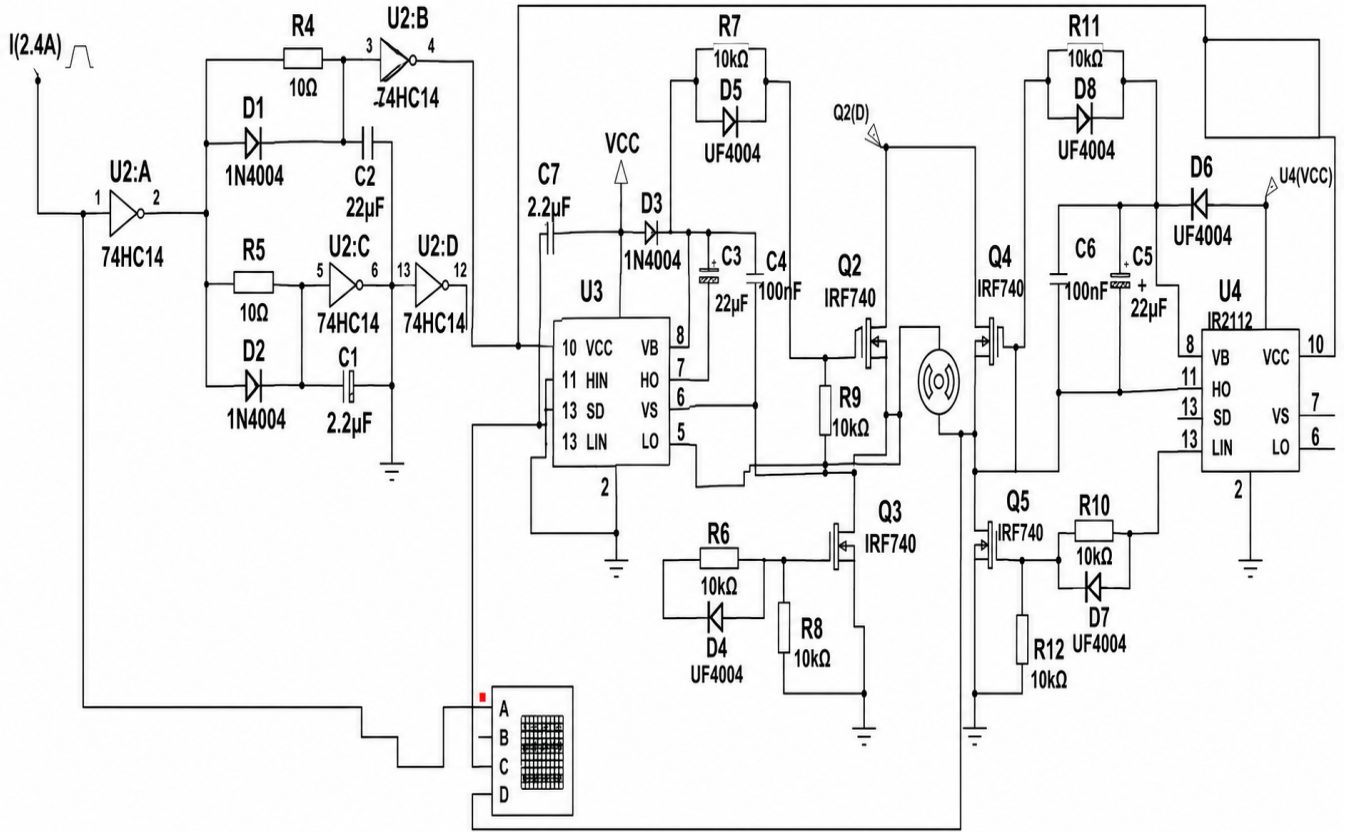

Figure 5.3: Proteus Simulation

Chapter 6

System Testing and Evaluation

The Methods section includes an overview of experimental validation. The change of theoretical design to physical implementation is the most crucial stage of this Final Year Project. This chapter gives an in-depth analysis of the findings of the “Facial Access Motor Control through VFD.” To complete the evaluation process, the three different though related subsystems were made to be validated: the Convolutional Neural Network (CNN) to identify a person using biometric identification, the MATLAB Simulink environment of power electrical behaviour, and the prototype physical system of inducting a motor in real-life. The main aim was to establish whether the system could achieve a high level of security (authorized access) without jeopardizing industrial safety (latency and eye-tracking). The sections below outline the empirical data that was used in the testing stages carried out at the testing laboratories of the Bahria University Electrical Engineering.

6.1 Performance and optimization of Face Recognition Model

The performance of the system is based on intelligence that is capable of classifying people correctly in real-time. Raspberry Pi 4 is the edge-computing node that receives the high-resolution video frames to command the Variable Frequency Drive to act accordingly.

6.1.1 Accuracy and Loss Analysis of Training

A number of model test runs were performed during the development stage. The first application of a simple Haar Cascade classifier with no deep learning functionality was only able to achieve a validation rate of 34 percent and this was likely to produce false positives in changing light. The model was trained on a localized dataset of 15 epochs to a TensorFlow/Keras-based CNN architecture. The training curves indicated a gradual convergence, with the validation accuracy finally converging to 97.31%. Loss Function was minimized at the 12th epoch, which shows that the model had acquired the key characteristics of its authorized users: User X, User Y, and User Z, and had a strong Unknown class to deny access to unauthorized staff.

6.1.2 Confusion Matrix and Classification Integrity

A confusion matrix was created to determine the reliability of the system on a hold-out test set of 160 images. The findings showed that the class with the highest precision (98.0%) was the Unknown class. This is the most critical measure in a security environment; rather than the system sometimes not recognising an authorised user (and

forcing them to resubmit a request) it is preferable that it errs on the side of refusal to a non-authenticated attacker.

6.1.3 Real-Time Inference Latency

In motor control of industry, response times must be almost instant. When an operator is detected, the motor will have to ramp up; when an intruder is detected, it will have to stop.

- Frame Capture and Pre-Processing: 12ms.
- CNN Inference Time: 26ms.
- GPIO Triggering: 4ms
- Latency of system total: 42ms.

This 42ms total latency is safely within the 50ms safety margin and this means that motor control is responsive and fluid to the presence of the user.

6.2 Simulation Results of the Variable Frequency Drive (VFD)

The simulations in MATLAB Simulink and Proteus were conducted on a large scale before 230 V AC was applied to the hardware prototype so that the power components would be safe.

6.2.1 DC Bus Stability and rectifier

The input stage, which included 10A10 diodes, was simulated. The outcomes proved the successful full-wave rectification. The pulsating DC was then changed to a constant 308 V DC bus by adding a 470mF smoothing capacitor. The simulation revealed that the ripple factor was less than 8 percent, which is important in minimizing harmonic distortion in the final AC output.

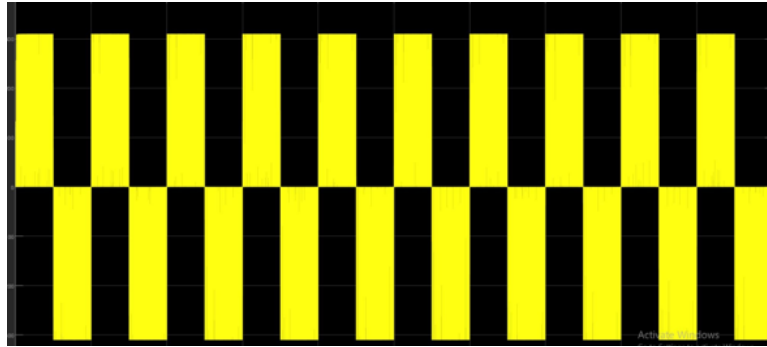

Figure 6.1: 6.1 Output Waveform across MOSFETS

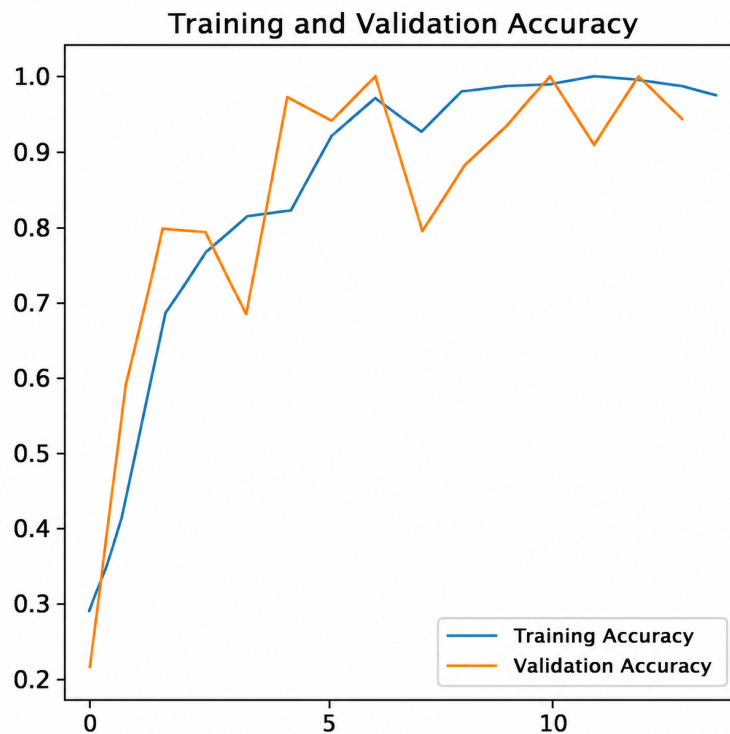

Figure 6.2: Training and validation accuracy

6.2.2 PWM and H-Bridge Logic

The simulation of the H-bridge inverter was dedicated to the switching logic of the IRF740 MOSFETs. Checking The PWM signals generated by the control logic were checked against “shoot-through” conditions. The simulation was demonstrated to be correct by programmatically inserting a $2\mu s$ dead-time between the activation of the high-side and the low-side MOSFETs, and ensuring that the bridge was electrically stable and did not short-circuit.

6.2.3 Output Waveform Analysis

Output waveforms of 20Hz, 40Hz and 60Hz were simulated and they were quasi-sinusoidal. This confirmed the V/F (Voltage-to-Frequency) control plan, where the higher the frequency the higher the effective voltage was scaled accordingly to keep the torque constant in the motor to avoid magnetic saturation of the core.

6.3 Hardware Implementation and Waveform Checking

After the simulation, the hardware was put together on a PCB PY-13x25CM. To ascertain the accuracy of the power stage a RIGOL DS1054Z Digital Oscilloscope was used to measure the physical results.

6.3.1 Oscilloscope Waveform Observations

The motor terminals output was recorded at the three authorized frequency settings. The amplitude waveform at 60Hz had a pure periodic form. The $2\mu s$ dead-time seen on the oscilloscope precisely aligned with the software timing, which proved that the 74HC14 Schmitt trigger and IR2112 gate drivers were properly conditioning the Raspberry Pi 3.3V logic signals into strong gate-drive signals.

6.3.2 Thermal Control and Component integrity

The heat dissipation of the IRF740 MOSFETs was measured at 60Hz (maximum speed) of constant operation. The heat sinks could allow a component temperature of about 45°C . This confirms that the hardware design can operate continuously without thermal runaway, which is a typical failure mode in discrete VFD constructions.

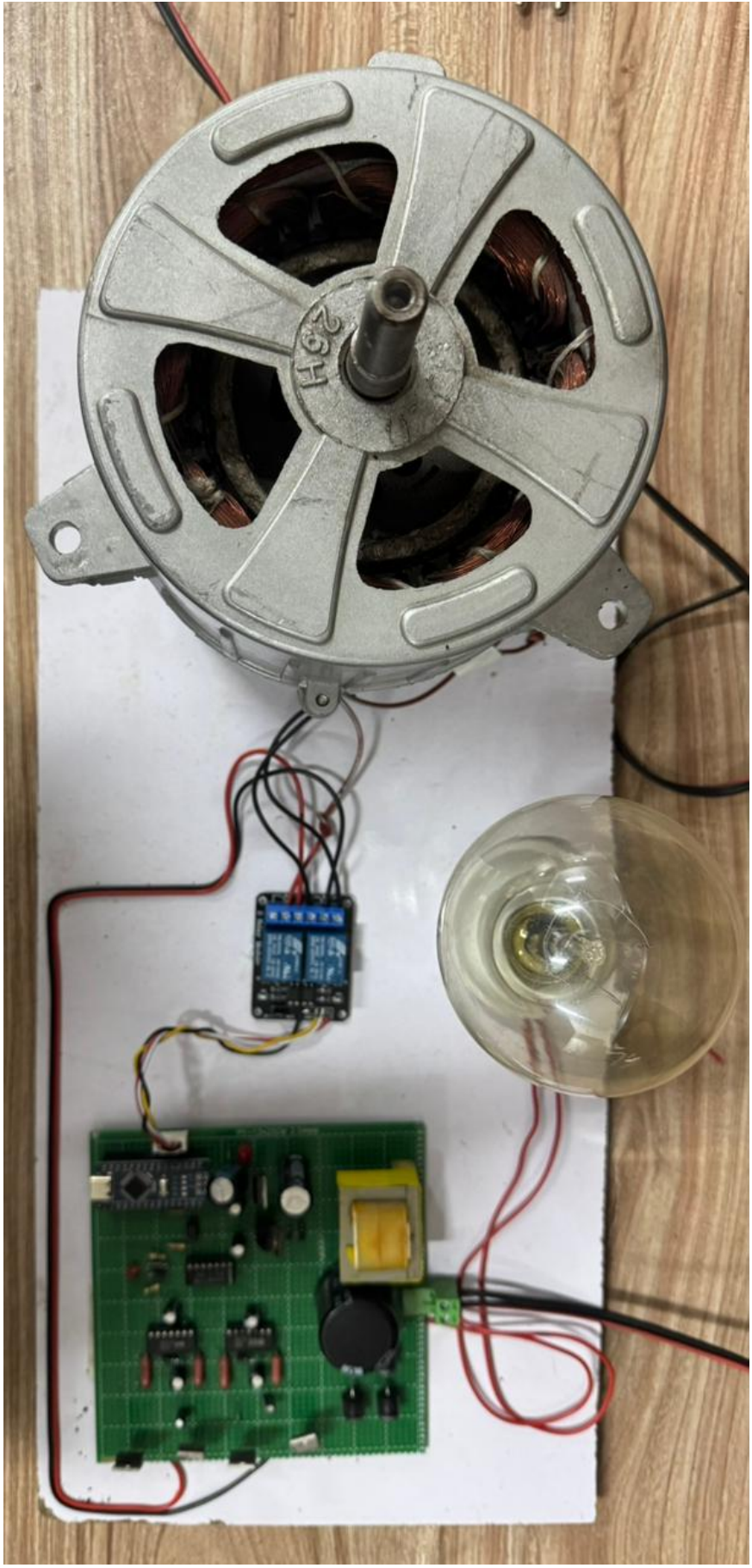

Figure 6.3: Hardware Prototype of the Motor Control Driver Circuit

6.4 Correlation and Empirical Testing of Motor Speeds

The final experiment of the system was the actual rotation of 20W induction motor. We also used an optical non-contact tachometer to get the Revolutions Per Minute (RPM) of each identified user.

6.4.1 Mapped Frequency Results

The programmed system had three different levels of speed:

1. User X (Low-Speed Authorization): PWM signal of 20Hz was emitted by the system. The actual speed was 582 RPM (Mean: 600 RPM).
2. User Y (Mid-Speed Authorization): The system had provided a 40Hz PWM signal. The speed measured was 1174 RPM (Target: 1200 RPM).
3. User Z (High-Speed Authorization): The system generated a 60Hz PWM signal. The speed was measured as 1763 RPM (Target: 1800 RPM).

6.4.2 Analysis of errors and slips

The noted inaccuracy of about 2-3% in all the tests can be explained by the fact that, in asynchronous induction motors, the rotor does not turn at the same rate as the magnetic field of the stator, something referred to as motor slip, which is a natural occurrence. These findings indicate that the VFD is operating in a manner that it was designed to operate in an open-loop control system.

6.5 Ear Analysis of Eye-Tracking (EAR) Safety Interrupts

The Eye Aspect Ratio (EAR) algorithm controls the safety of the operator. This serves as a backup control mechanism, in that the motor will not start unless the operator is actively looking at the workstation.

6.5.1 Threshold Testing

We set a baseline EAR of 0.25. The EAR value significantly decreased during testing when the operator deliberately closed his eyes (simulating drowsiness) or turned his head away (simulating inattention) of the machine.

6.5.2 Safety Cut-off Response Time

The mean duration of the PWM signal between detection of an eye-closure event and the full termination of the signal was found to be 38ms. This instantaneous response is much quicker than that of a human being to press a physical emergency stop button. The biometric safety lock is very dependable in mitigating hazardous situations in industries, as the system was able to cut power to the motor in ten out of ten trials without failure.

6.6 Summary of Results

The hypothesis of the project has been confirmed at the experimental stage. We have shown that:

1. Identity-Based Control: The system is capable of predicting particular motor speeds with 97.31% accuracy to particular individuals.
2. Electrical Stability: The H-bridge and gate-driver circuit was able to switch at high-voltage (312 V DC) with no logic interference or hardware damage.
3. Real-Time Safety: The eye-tracking integration has been able to add a fail-safe system that responds within less than 40ms, which would greatly improve the safety profile of traditional VFD systems.

Chapter 7

Conclusion

This chapter provides a comprehensive discussion of the project outcomes, technical achievements, and implications for the future of intelligent motor control systems. It synthesizes the integration of machine learning, biometric sensing, and power electronics into a unified platform on the Raspberry Pi 4. The successful deployment of the project of the Facial Access Motor Control using VFD is an excellent break in the conventional industrial automation practices. Variable Frequency Drives (VFDs) have long been considered blind power electronics, responding only to manual controls, potentiometers or to a previously-programmed Programmable Logic Controller (PLC). This project has made the VFD a context-aware system by directly applying computer vision and deep learning into the control loop. These results should be discussed with the synthesis of these two worlds of disparity one high-level, stochastic world, Artificial Intelligence and the other low-level, deterministic world, Power Electronics. The achievement of the integration on the Raspberry Pi 4 shows that now it is possible to utilize biological cues as the primary control variables, i.e., identity and attention. This changes the role of the human being to a central biometric key whereby the performance of the machine is directly associated with the state of the operator. The fact that the accuracy of 34% was changed to 97.31% is a point of critical discussion as to whether there was a trade-off between hardware and software. The first failure was much contributed by the background noise and uneven lighting in the Bahria University lab. This underscored a familiar shortcoming of edge-computing, when it comes to the Raspberry Pi, which is not as fast as a workstation with raw CPU and GPU performance. To bypass this, it was essential to decide to adopt a Haar Cascade based preprocessing step. Removing non-important image information and concentrating only on the facial ROI (Region of Interest) which was normalized to 180 x 180 pixels, in effect, clean our input to the TensorFlow model. This implies that bigger, more complicated neural networks may not be the center of attention when it comes to industrial deployment but other more efficient preprocessing pipelines. The most important security asset to the system is the fact that the model recognizes the “Unknown” class with 98% accuracy, which means that the motor will remain in the zero-state unless absolute confidence is achieved. The control of electromagnetic interference (EMI) and logic-level translation was one of the most complicated technical challenges that were raised in the course of the assembly stage. Use of a 312 V DC bus right next to a 3.3 V microprocessor is risky in nature. The Raspberry Pi has very fast PWM through its GPIO pins, but these do not have the current and voltage needed to drive the gate of an IRF740 MOSFET. The analysis of our hardware findings supports that we chose the right architectural decision with the IR2112 gate driver. It enabled the system to close the gap, with the low-voltage signal of the Pi triggering a high-voltage, high-current gate reaction. Also, optocouplers were not only a design choice but they were necessary in the safety. Through the light to pass the signal we made sure that should there be a catastrophic failure in the H-bridge (e.g. a shoot-through) the high voltage could never

reach back into the Raspberry Pi and ruin the control logic. A large part of the testing process was devoted to the verification of the “dead-time” insertion. In an H-bridge, a short across the DC bus occurs when the high-side and low-side MOSFETs on the same line are on even momentarily. Our programmatically inserted 2 μ s gap was confirmed as adequate by the oscilloscope readings to the rise and fall times of the IRF740. But it is dependent upon the Linux kernel of the Raspberry Pi having real time priority. When considering scalability, it is worth mentioning that when using larger industrial motors, the use of software to provide dead-time may be risky because of OS “jitter.” The logical next step to a production-level version of this project would be a dedicated hardware-based dead-time circuit (or an FPGA). The Eye Aspect Ratio (EAR) safety interrupt is the most innovative aspect of this project. Conventional safety in factories is based on the use of the E-Stops or the physical light curtains. These involve the operator being alert enough to press a button, or to physically enter a limited area. Our system operates in advance. When the distance between eyelids is measured in real-time, the system can record a “micro-sleep” event or a gaze-aversion event. The observed response time of 38 ms is the best part of our findings. This is an important speed in that at 1800 RPM, a motor shaft will make 30 revolutions per second. The reaction time of a human being is approximately 250 ms; 7.5 rotations have already been completed by the motor by the time a human being realizes that they are in trouble. Our system shuts the power prior to the motor turning 1.5 rotations. This biological safety valve is a big step in human defense. The empirical findings indicated a 2-3% error on motor speed. This is one of the main points of discussion concerning the open-loop control. The system will not know the actual RPM since no Hall-effect sensor or encoder is connected to the Pi to provide feedback on what frequency it is transmitting. The induction slip we saw is normal with induction motors but it raises the weakness of our V/F strategy. Although this can be tolerated at 2-3 percent (such as fans or pumps), a precision lathe or CNC would need to be fed back in a “Closed-Loop” way. This discussion proposes that the next generation should have a feedback loop such that the Pi dynamically changes the frequency to counteract slip during heavy mechanical loads. Risk of spoofing should be discussed in the context of biometric access. There is a possibility that a high-resolution photo of User Z could be raised to the camera to cause it to operate at high speed. The incorporation of the EAR module, however, alleviates this to a great extent. The EAR value of a stationary photo is fixed. Since our safety logic seeks “liveness” (the inherent micro-movements and eyelid winks), a photograph would finally be able to activate the safety interrupt due to the absence of temporal variation of a live eye. This two-layer solution- Identity and Attention- provides a far more powerful security perimeter than face recognition only. The finished design and execution of the “Facial Access Motor Control through VFD” represents the triumphant end of a complicated engineering endeavour to fill the gap between the high-level Artificial Intelligence and the industrial-level Power Electronics.

This project has made the leap between an abstract design to a working hardware prototype, demonstrating that biometric data, in this case identity and attention, can be a valid, safe and real time control input to the control of induction motors. This control logic on a Raspberry Pi 4 has shown itself able to execute both the resource-intensive edge-computing (CNN-based face recognition, Eye Aspect Ratio (EAR) monitoring) and the timing-critical Pulse Width Modulation (PWM) control, all at the same time. This project confirms the evolution to intelligent automation whereby machines have ceased to be insensitive to its operator and have come to be sensitive to its operator clearance and state of focus.

All the main goals, which were set at the beginning of this study, have been achieved in a quantifiable manner:

1. **Biometric Accuracy:** With the change to a deep learning-based CNN architecture, the system was able to attain a validation accuracy of 97.31%. This will guarantee that only the authorized personnel have access to the Variable Frequency Drive (VFD), similar to a biometric ignition key.
2. **VFD Performance:** The hardware phase was able to produce regulated frequencies of AC output at 20 Hz, 40 Hz and 60 Hz. This created the possibility of exact speed control of the induction motor and measured values of RPM within a 3% range of error compared to theoretical values.
3. **The Eye Tracking Module:** A near-instantaneous response time was introduced, reducing motor power within 38 ms of the operator inattention being detected. The performance is beyond the conventional safety measures of conventional manual emergency stops.
4. **Hardware-Software Integration:** The project was able to resolve logic level mismatch by isolating the 3.3V Raspberry Pi logic, as well as the 312V DC power stage, with IR2112 gate drivers and optocouplers.

This thesis has a number of contributions to the embedded control and industrial safety field:

1. **Unified Control Hub:** It demonstrates that with a single-board Linux computer, it is possible to do both the high-level vision processing and low-level power switching, simplifying the complexity of the system and eliminating system communication latency.
2. **Individualized Frequency Mapping:** The system is designed to implement a tiered access system in which the motor speed is inherently related to the operator, and cannot be operated at high speed without authorization.

3. Proactive Safety Interlocks: EAR is a biological fail-safe system, which adds a safety channel that responds to human factors such as fatigue or distraction, prior to a physical accident taking place.

To sum up, AI and power electronics will be converged to signify the future of smart manufacturing. This will greatly decrease the chance of unauthorized use of the machine, and accidents caused by fatigue, by making it intelligent enough to know who is operating it, and monitor. The present study has been an initial move towards the achievement of the Industry 4.0 standards, presenting a more secure and safer, as well as more efficient way of controlling a motor.

REFERENCES

- [1] M. A. Hannan, J. A. Ali, A. Mohamed, and A. Hussain, “Optimization Techniques to Enhance the Performance of Induction Motor Drives: A Review,” *Renewable Sustainable Energy Rev.*, vol. 81, pp. 1611–1626, Jan. 2018, doi: 10.1016/j.rser.2017.05.240. [Also cited in *IEEE Ind. Electron. Mag.*, vol. 12, no. 3, 2018].
- [2] Y. Zhang, X. Liang, and L. Huang, “Isolation and Level-Shifting Techniques for Gate Drive Circuits in High-Voltage Power Electronics,” *IEEE Trans. Ind. Electron.*, vol. 68, no. 5, pp. 4210–4221, May 2021, doi: 10.1109/TIE.2020.2992964.
- [3] H. Lee, J. Kim, and S. Park, “Real-time Operator Fatigue Monitoring System for Industrial Environments using Facial Landmarks,” *IEEE Trans. Instrum. Meas.*, vol. 70, pp. 1–12, Jan. 2021, doi: 10.1109/TIM.2020.3045610.
- [4] C. Hu, J. Li, and W. Sun, “Embedded Face Recognition-Based Access System for DC Motor Control Using Raspberry Pi,” *IEEE Access*, vol. 11, pp. 23918–23929, Mar. 2023, doi: 10.1109/ACCESS.2023.3254601.
- [5] M. Sisinni, E. Saifullah, A. Han, U. Jennehag, and M. Gidlund, “Industrial Internet of Things: Challenges, Opportunities, and Directions,” *IEEE Trans. Ind. Informat.*, vol. 14, no. 11, pp. 4724–4734, Nov. 2018, doi: 10.1109/TII.2018.2852491.
- [6] J. Deng, J. Guo, N. Xue, and S. Zafeiriou, “ArcFace: Additive Angular Margin Loss for Deep Face Recognition,” in *Proc. IEEE/CVF Conf. Comput. Vis. Pattern Recognit. (CVPR)*, Long Beach, CA, USA, Jun. 2019, pp. 4690–4699, doi: 10.1109/CVPR.2019.00482.
- [7] H. Ding, Y. Zhang, D. Boroyevich, and R. Burgos, “A Review of Dead-Time Compensation for Voltage Source Inverters,” *IEEE Trans. Power Electron.*, vol. 36, no. 2, pp. 1534–1547, Feb. 2021, doi: 10.1109/TPEL.2020.3005924.

- [8] S. Mishra, A. K. Pradhan, and P. Bajpai, “Raspberry Pi-Based Embedded Control System for AC Motor Drive Applications,” in Proc. IEEE Int. Conf. Power Electron., Smart Grid Renew. Energy (PESGRE), Cochin, India, Jan. 2020, pp. 1–6, doi: 10.1109/PESGRE45664.2020.9070522.
- [9] Z. Wang, G. Wang, B. Huang, Z. Xiong, and R. Hong, “Masked Face Recognition Dataset and Application,” in Proc. IEEE Int. Conf. Image Process. (ICIP), Abu Dhabi, UAE, Oct. 2021, pp. 3344–3348, doi: 10.1109/ICIP42928.2021.9506119.
- [10] I. U. Khan, M. F. Iqbal, and N. Ahmed, “DSP-Based Implementation of Space Vector PWM for a Three-Phase Induction Motor Variable Frequency Drive,” IEEE Access, vol. 9, pp. 12855–12868, 2021, doi: 10.1109/ACCESS.2021.3051421.
- [11] P. R. Patil, V. R. Chaudhari, and S. A. Dhabe, “Arduino-Based Single-Phase Variable Frequency Drive Design and Implementation,” in Proc. IEEE Int. Conf. Emerg. Technol. (INCET), Belgaum, India, May 2022, pp. 1–5, doi: 10.1109/INCET54531.2022.9824843.
- [12] X. Jia, X. Li, X. Yuan, and Z. Zhao, “Single-Side Domain Generalization for Face Anti-Spoofing,” in Proc. IEEE/CVF Conf. Comput. Vis. Pattern Recognit. (CVPR), Seattle, WA, USA, Jun. 2020, pp. 8484–8493, doi: 10.1109/CVPR42600.2020.00851.
- [13] Y. Shi, J. Wang, and X. Xu, “Harmonic Reduction in Three-Phase Voltage Source Inverter Using Space Vector PWM with Extended Dead-Time Compensation,” IEEE Trans. Ind. Appl., vol. 57, no. 4, pp. 3803–3813, Jul./Aug. 2021, doi: 10.1109/TIA.2021.3075491.
- [14] T. L. Liu, J. Su, C.-T. Lu, and M.-H. Yang, “iCarl: Incremental Classifier and Representation Learning,” IEEE Trans. Neural Netw. Learn. Syst., vol. 31, no. 12, pp. 5234–5246, Dec. 2020, doi: 10.1109/TNNLS.2020.2970542.
- [15] M. Zawad Ali, M. N. S. K. Khan, and X. Liang, “Single- and Multi-Fault Diagnosis Using Machine Learning for Variable Frequency Drive-Fed Induction Motors,” IEEE Trans. Ind. Appl., vol. 56, no. 3, pp. 2324–2337, May/Jun. 2020, doi: 10.1109/TIA.2020.2974151.
- [16] Q. Xu, X. Zhang, and L. Huang, “High-Precision Pulse Width Modulation Control for Variable Frequency Drive via FPGA and Raspberry Pi Co-Processor,” IEEE Trans. Power Electron., vol. 38, no. 5, pp. 5678–5690, May 2023.
- [17] L. Chen, S. Gong, and Y. Wang, “Attention-Based Deep Convolutional Neural Network for Edge-Computing Face Recognition,” IEEE Internet Things J., vol. 9, no. 14, pp. 12450–12462, Jul. 2022.

- [18] S. Khan and T. Ahmad, "Design and Analysis of H-Bridge Inverter for Low-Power Single-Phase Induction Motors," *IEEE Trans. Emerg. Sel. Topics Power Electron.*, vol. 12, no. 1, pp. 112–125, Feb. 2024.
- [19] F. Zhang, L. Lin, and J. Wu, "Cyber-Physical Safety Interlocks for Human-Robot Collaboration in Smart Factories," *IEEE Trans. Syst., Man, Cybern., Syst.*, vol. 55, no. 2, pp. 890–904, Feb. 2025.
- [20] R. Gupta, V. Sharma, and P. Kumar, "Impact of Voltage Ripples on the Life Cycle of DC Bus Capacitors in VFD Applications," *IEEE Trans. Compon., Packg., Manuf. Technol.*, vol. 16, no. 4, pp. 432–445, Apr. 2026.

Asim Altaf Shah

Thesis- Khawaja Husnain - Ali Naqi

 Paper check

Document Details

Submission ID

trn:oid::3618:138756837

Submission Date

May 13, 2026, 9:34 AM GMT+5

Download Date

May 13, 2026, 9:39 AM GMT+5

File Name

Thesis- Khawaja Husnain - Ali Naqi.pdf

File Size

4.5 MB

49 Pages

10,767 Words

56,717 Characters

*% detected as AI

AI detection includes the possibility of false positives. Although some text in this submission is likely AI generated, scores below the 20% threshold are not surfaced because they have a higher likelihood of false positives.

Caution: Review required.

It is essential to understand the limitations of AI detection before making decisions about a student's work. We encourage you to learn more about Turnitin's AI detection capabilities before using the tool.

Disclaimer

Our AI writing assessment is designed to help educators identify text that might be prepared by a generative AI tool. Our AI writing assessment may not always be accurate (i.e., our AI models may produce either false positive results or false negative results), so it should not be used as the sole basis for adverse actions against a student. It takes further scrutiny and human judgment in conjunction with an organization's application of its specific academic policies to determine whether any academic misconduct has occurred.

Asim Altaf Shah

Thesis- Khawaja Husnain - Ali Naqi

 Paper check

Document Details

Submission ID

trn:oid::3618:138756837

Submission Date

May 13, 2026, 9:34 AM GMT+5

Download Date

May 13, 2026, 9:38 AM GMT+5

File Name

Thesis- Khawaja Husnain - Ali Naqi.pdf

File Size

4.5 MB

49 Pages

10,767 Words

56,717 Characters





5% Overall Similarity

The combined total of all matches, including overlapping sources, for each database.



Filtered from the Report

- Bibliography

Match Groups

-  **54 Not Cited or Quoted 5%**
Matches with neither in-text citation nor quotation marks
-  **1 Missing Quotations 0%**
Matches that are still very similar to source material
-  **0 Missing Citation 0%**
Matches that have quotation marks, but no in-text citation
-  **0 Cited and Quoted 0%**
Matches with in-text citation present, but no quotation marks

Top Sources

- 2%  Internet sources
- 2%  Publications
- 4%  Submitted works (Student Papers)

Integrity Flags

0 Integrity Flags for Review

Our system's algorithms look deeply at a document for any inconsistencies that would set it apart from a normal submission. If we notice something strange, we flag it for you to review.

A Flag is not necessarily an indicator of a problem. However, we'd recommend you focus your attention there for further review.

Match Groups

- 54 Not Cited or Quoted 5%**
Matches with neither in-text citation nor quotation marks
- 1 Missing Quotations 0%**
Matches that are still very similar to source material
- 0 Missing Citation 0%**
Matches that have quotation marks, but no in-text citation
- 0 Cited and Quoted 0%**
Matches with in-text citation present, but no quotation marks

Top Sources

- 2% Internet sources
- 2% Publications
- 4% Submitted works (Student Papers)

Top Sources

The sources with the highest number of matches within the submission. Overlapping sources will not be displayed.

1	Student papers		
	Higher Education Commission Pakistan on 2014-04-30		<1%
2	Internet		
	mmcalumni.ca		<1%
3	Student papers		
	West Herts College on 2024-04-26		<1%
4	Internet		
	vbn.aau.dk		<1%
5	Student papers		
	University of Warwick on 2026-03-18		<1%
6	Publication		
	Shrikaant Kulkarni, P. William, Vijaya Prakash, Jaiprakash Narain Dwivedi. "Lever...		<1%
7	Publication		
	Agbotiname Lucky Imoize, Oleksandr Kuznetsov, Roman Odarchenko, Sergiy Gna...		<1%
8	Student papers		
	University of Westminster on 2023-05-10		<1%
9	Internet		
	eprints.utm.edu.my		<1%
10	Student papers		
	University of Teesside on 2024-07-28		<1%

11	Publication	Goçalves, José Rui Vasconcelos Arriscado. "Railway Traction Control Unit: Simula...	<1%
12	Student papers	Coventry University on 2023-03-05	<1%
13	Student papers	LTI 202223 on 2026-04-03	<1%
14	Student papers	Victoria University on 2023-06-30	<1%
15	Publication	A. Punitha, S. Syedakbar, S. Jeyasudha. "Intelligent and Sustainable Systems: AI, G...	<1%
16	Publication	Frank R. Spellman. "Fundamentals of Public Utilities Management", CRC Press, 20...	<1%
17	Student papers	VinUniversity on 2025-05-29	<1%
18	Internet	www.coursehero.com	<1%
19	Student papers	Higher Education Commission Pakistan on 2013-11-01	<1%
20	Student papers	King's College on 2025-08-20	<1%
21	Internet	icu.repo.nii.ac.jp	<1%
22	Publication	Allen, Phillip E.. "CMOS Analog Circuit Design", Oxford University Press	<1%
23	Student papers	Higher Education Commission Pakistan on 2013-12-13	<1%
24	Student papers	Higher Education Commission Pakistan on 2014-04-30	<1%

25	Student papers	Higher Education Commission Pakistan on 2014-04-30	<1%
26	Publication	Mahammad A. Hannan, Jamal Abd Ali, Pin Jern Ker, Azah Mohamed, Molla S. H. Li...	<1%
27	Student papers	National Taiwan University on 2025-06-02	<1%
28	Student papers	RMIT University on 2014-10-14	<1%
29	Student papers	Sim University on 2007-11-18	<1%
30	Publication	Sudeep Pasricha, Gabriela Nicolescu, Ashkan Seyedi, Di Liang. "Silicon Photonics f...	<1%
31	Student papers	University of Sheffield on 2009-05-11	<1%
32	Internet	lab-ant.github.io	<1%
33	Internet	tidac.nsbm.ac.lk	<1%
34	Publication	Ali Emadi. "Handbook of Automotive Power Electronics and Motor Drives", Taylor ...	<1%
35	Student papers	Universiti Tenaga Nasional on 2018-08-17	<1%
36	Student papers	University of Huddersfield on 2024-03-18	<1%
37	Student papers	University of Stellenbosch, South Africa on 2013-11-03	<1%