

# Digital Twin

By

Muhammad Bilal

Enrollment No. 01-133192-069

Muhammad Shamim

Enrollment No. 01-133192-094

Muhammad Farhan

Enrollment No. 01-133192-077

**Supervised By**

Engr. M. Hassan Danish Khan



Session 2019-23

A Report is submitted to the Department of Electrical Engineering,  
Bahria University, Islamabad.

In partial fulfillment of requirement for the degree of BS(EE).



**Bahria University Islamabad**  
**Department Electrical Engineering**

---

**Dated: 15<sup>th</sup> May, 2023.**

**CERTIFICATE**

**We accept the work contained in the report titled (Digital Twin) as a confirmation to the required standard for the partial fulfillment of the degree of BEE.**

\_\_\_\_\_  
**M. Hasan Danish Khan**  
Project Coordinator  
Date: \_\_\_\_\_

\_\_\_\_\_  
**Engr. M Hasan Danish**  
Supervisor  
Date: \_\_\_\_\_

\_\_\_\_\_  
**Dr. Junaid Imtiaz**  
Internal Examiner  
Date: \_\_\_\_\_

\_\_\_\_\_  
**Dr Aleem Khaliq**  
External Examiner  
Date: 15/05/23

\_\_\_\_\_  
**Head of Department (EE)**  
Date: \_\_\_\_\_



# Dedication

We would like to dedicate this project to all Farm workers and people related to the agricultural sector, which caused them a lot of losses in crop production and harvesting due to a lack of technological advancement and poor management of a field. Every season such losses bring food hunger and destruction to the agricultural sector. We would love to present this prototype for smart monitoring and control of such field hazard events, and it is the best way to contribute towards society by our profession.

## Acknowledgments

We are very Grateful to Al-Mighty Allah, the Supreme Generous, Who provided us strength and skill to grasp our goal. It is a great pleasure to acknowledge our deepest thanks to our family for their continuous love and support. We owe a considerable debt to a large number of people who either directly or indirectly helped us during various phases of our Final Year Project. It was an entirely new experience full of challenges and excitement.

We would like to express our greatest gratitude and sincere appreciation to our Supervisor, Engr. M. Hassan Danish Khan, for his constant encouragement, comprehensive advice and his kind supervision till this project came into existence.

## Abstract

A digital twin is a virtual representation of a physical object or system used for simulation, analysis, and monitoring. It uses data from sensors and other sources to create a digital model of the object or system, allowing for the analysis of its performance, behavior, and potential issues. Digital twins can be used in a variety of industries, including manufacturing, healthcare, and urban planning, to improve efficiency, reduce downtime, and optimize processes. For this project, we are implementing a smart agricultural system which refers to a virtual representation of a farm, its resources (such as land, crops, and equipment), and its processes (such as planting, watering, and harvesting). This digital representation is created by collecting data from sensors and using that data to create a virtual model of the farm. Using a digital twin in a smart agricultural system provides a virtual representation of a farm and its processes, allowing for Improved crop management: By monitoring crop growth and soil conditions in real-time, farmers can optimize irrigation and fertilization to improve crop yield and quality. Predictive maintenance: A digital twin can be used to monitor the performance of equipment and predict potential failures, allowing farmers to schedule maintenance proactively and minimize downtime. Better resource management: By analyzing data from the digital twin, farmers can optimize the use of resources such as water, fertilizer, and energy, reducing costs and minimizing environmental impact. Enhanced decision-making: By providing real-time data and insights, a digital twin can help farmers make more informed decisions about planting, harvesting, and resource management. Increased efficiency and profitability: By improving crop management, resource utilization, and decision-making, a digital twin can help farmers increase the efficiency and profitability of their operations.

# Contents

<b>1</b>	<b>Introduction</b>	<b>1</b>
1.1	Project Background: . . . . .	2
1.2	Project Description: . . . . .	3
1.3	Project Objectives: . . . . .	5
1.4	Project Scope: . . . . .	6
<b>2</b>	<b>Literature Review</b>	<b>7</b>
2.1	History of Digital Twin . . . . .	8
2.2	Purpose of this technology . . . . .	9
2.3	Benefits of using Digital Twin Technology . . . . .	11
2.4	Basic design concept of Digital Twin . . . . .	13
2.5	Enabling Digital Twin Technology . . . . .	15
2.6	Challenges required for implantation of a digital twin? . . . .	17
2.7	Digital twin in the agriculture sector . . . . .	19
2.8	lot based smart agriculture monitoring system vs digital twin smart agriculture monitoring system . . . . .	21
2.9	Limitation of this technology(Digital Twins) . . . . .	23
<b>3</b>	<b>Requirement Specifications</b>	<b>26</b>
3.1	Existing System . . . . .	27
3.2	Proposed System . . . . .	29
3.3	System Requirements(Hardware Spec) . . . . .	30
3.3.1	RPi 4(Raspberry Pi) . . . . .	32
3.3.2	Moisture Sensor(YL-100) . . . . .	34
3.3.3	DHT22 Temperature And Humidity Sensor . . . . .	38

3.3.4	Flame Detector . . . . .	40
3.3.5	Luminosity Sensor . . . . .	41
3.3.6	Analog-to-Digital Converter(ADS1115) . . . . .	43
3.3.7	Display And Inputs . . . . .	45
3.3.8	Relay Switch . . . . .	46
<b>4</b>	<b>System Design</b>	<b>48</b>
4.1	System Architecture(Design Process/Procedure) . . . . .	49
4.1.1	Farm/Field(Physical Environment) . . . . .	50
4.1.2	Cloud Service Platform . . . . .	50
4.1.3	Digital Representation (Virtual Environment) . . . . .	50
4.2	Design Constraints . . . . .	52
4.3	Design Methodology . . . . .	53
<b>5</b>	<b>System Implementation</b>	<b>56</b>
5.1	System Architecture(Implementation Process) . . . . .	57
5.2	Hardware Setup(Sensors Configuration And Coding) . . . . .	58
5.3	Software Setup(Microsoft Azure Platform: Digital Twin) . . . . .	60
5.3.1	Azure Digital Twin . . . . .	60
5.3.2	Digital Twin Explorer . . . . .	62
5.3.3	Digital Twin Storage Account . . . . .	65
5.3.4	Digital Twin 3d Scenes( Virtual Model Representation) . . . . .	66
5.3.5	Elements In 3d scene . . . . .	69
5.3.6	Azure IOTHUB . . . . .	71
5.4	Event Hub And Clustering(Azure Data Explorer) . . . . .	73
5.4.1	Azure Function App . . . . .	74
5.5	Logic App . . . . .	75
<b>6</b>	<b>System Testing and Evaluation</b>	<b>76</b>
6.1	Cloud Service Testing And Analysis . . . . .	77
6.1.1	Initial Analyses and Results . . . . .	77
6.1.2	Updated/Final Analyses and Results . . . . .	82

<b>7 Conclusion</b>	<b>88</b>
<b>References</b>	<b>90</b>
<b>A User Manual</b>	<b>93</b>
A.1 RB-PI4 External Information . . . . .	94
A.1.1 RB-PI4 Data-sheets and pin-out board . . . . .	94
A.1.2 RB-PI4 OS(Ubuntu) and important libraries . . . . .	97
A.2 Azure Platform Services used and Software Usage . . . . .	99

# List of Figures

3.1 Existing subsystem layout [1] . . . . .	28
3.2 Existing system prototype [1] . . . . .	28
3.3 Raspberry Pi 4 [2] . . . . .	32
3.4 Moisture Sensor Images [3] . . . . .	34
3.5 Gas Sensor(MQ-135) Images [4] . . . . .	36
3.6 DHT-22 Sensor Images [5] . . . . .	38
3.7 Flame Sensor Module [6] . . . . .	40
3.8 Luminosity Sensor Module [7] . . . . .	41
3.9 ADC(ADS1115) IC Images [8] . . . . .	43
3.10 Display and inputs . . . . .	45
3.11 Relay Switch Module [9] . . . . .	46
4.1 System basic Architecture . . . . .	49
4.2 Project CAD design . . . . .	50
4.3 System Software overview [10] . . . . .	51
4.4 System Design Hardware And Software . . . . .	55
5.1 System Architecture(implementation) . . . . .	57

5.2	Sensors Interfacing . . . . .	58
5.3	Sensors Coding . . . . .	59
5.4	Azure Digital Twin Instance . . . . .	61
5.5	Azure Digital Twin Explorer . . . . .	63
5.6	Azure Digital Twin Explorer . . . . .	64
5.7	Azure Digital Twin Storage . . . . .	65
5.8	Azure Digital Twin 3d Scene . . . . .	67
5.9	Azure Digital Twin 3d Scene . . . . .	68
5.10	3d Scene Elements Overview . . . . .	70
5.11	Azure IOT Cloud service . . . . .	72
5.12	Azure IOT Cloud service . . . . .	73
5.13	Azure IOT ingest Function . . . . .	74
5.14	Azure Notification Service . . . . .	75
6.1	Adding Connection to Azure IoT Explorer to observe in-coming telemetry . . . . .	78
6.2	DeviceId:Field is used as a device to cloud server Azure IoT Explorer(No Message Read) . . . . .	78
6.3	IOTHub Overview (No Message Read) . . . . .	79
6.4	Azure Function App to transfer telemetry to Azure Explorer (No Message Read) . . . . .	79
6.5	Service Bus Event Notifier Overview (No Messages Read) . . . . .	80
6.6	Logic Hub Metrics Overview (No Message Read) . . . . .	80
6.7	Azure Digital Twin Explorer Graph Overview (No Values Updated By default zero indication) . . . . .	81
6.8	Azure Digital Twin 3d scene Overview(No Values updated: system model values updates if Explorer Graph is updated) . . . . .	81
6.9	RBPI4 Code status: Running . . . . .	82
6.10	RBPI4 Code status: Running . . . . .	82
6.11	RBPI4 Code status: Running (Sending Notification) . . . . .	83
6.12	DeviceId:Field Azure IoT Explorer (Message Read) . . . . .	83
6.13	IOTHub Overview (Message Read) . . . . .	84

6.14	Azure Function App to transfer telemetry to Azure Explorer (Message Read) . . . . .	84
6.15	Service Bus Event Notifier Overview (Messages Read) . . .	85
6.16	Logic Hub Metrics Overview (Message Read) . . . . .	85
6.17	Received Notification Screenshots . . . . .	86
6.18	Azure Digital Twin Explorer Graph Overview (Values Up- dated By default zero indication) . . . . .	87
6.19	Azure Digital Twin 3d scene Overview(Values updated: sys- tem model values update if Explorer Graph is updated) . .	87

## List of Tables

3.1	Digital Farm Components . . . . .	30
3.2	RBPi 4 Model Specs [2] . . . . .	33
3.3	SM Pin Configuration [3] . . . . .	35
3.4	GS-mq135 Pin Configuration [4] . . . . .	37
3.5	DHT22 Pin Configuration [5] . . . . .	39
3.6	Flame Detector Pin Configuration [11] . . . . .	40
3.7	LDR Sensor Module Pin Configuration [7] . . . . .	41
3.8	ADS-1115 Pin Configuration [8] . . . . .	44
3.9	Relay Switch Module Pin Configuration [9] . . . . .	47



# Chapter 1

## Introduction

## 1.1 Project Background:

In the late 1700's, 1800's the agriculture sector was not developed or familiar with the technologies being used for the proper production of crops and their maintenance. They used the old techniques they were familiar with, mostly buffalos and handmade tools. But with the passage of time, the world has developed its agriculture sector with other sectors as well with the help of new technologies. As with the revolution of Industry 4.0 across the world, every country has achieved many developments in all sectors of technology. But as concerned with Pakistan as our mother land with the increase in technology, somehow the agriculture sector of Pakistan is not so much developed with respect to the other countries. As we are now living in the 21st century, our country's agriculture sector is not familiar with the increasing technologies in the agriculture domain due to a lack of education or lack of proper channels or training of our farmers. This project Digital Twin Technology in Smart Agriculture System, deals with the data collection of the production of crops using IOT-based sensors, this collected data can be stored in the cloud server. The system is capable of making the predicted values and decisions by comparing the data stored with the accurate data that is good for the production of plants and crops. The gas sensor gives us the reading of the amount of gases that are good for production. The moisture sensor gives us the reading of moisture in the soil. All the given data can be seen through the dashboard of the android app that we use in this project to record the sensors shown in the meter.

## 1.2 Project Description:

Digital Twin Technology is a way of representing the physical appearance and behavior of an object in real-time and provides its specifications in a virtual space. Using Digital Twins Technology in Smart farming as a median permits splitting physical process from its plotting and controlling it in a virtual space. Therefore, it can enhance the farmers to control the operations in some way by providing real-time digital data instead of having to depend on the manual task and observation. It will help to automate the whole process in the digital domain in your smart mobile application. In this way the farmers are allowed to act rapidly in case of threshold value increases or decreases and to trigger effects of interruptions on the basis of real-time digital data [12]. According to the Food and Agriculture Organization (FAO) research, the need of food will increase by 40% from 2012 to 2050 to unite the essential requirement of food for the rapidly growing population of the world, which has almost crossed 78 billion people by 2030 [13]. This project will deal with the low-cost so that every farmer can easily take advantage of this for the proper crop production. This project will help him with sufficient training and provide skills to understand the sensor's measurement that could be displayed on the app so it can provide proper maintenance to its fields. The IOT-based sensors are directly connected to the Raspberry pie, through which data is stored on the cloud server and the readings of the sensors can be shown on the mobile app's dashboard. In producing and manufacturing food, we have to look at the raw material first. As the raw material in the agricultural sector/domain to produce food is soil for the constraints of soil based on the specification of land where we want to grow the food. So, a Digital Twin Technology in Smart farming requires us to understand and evaluate

everything about the volume, wealth, and reserve of the soil [14]. Like the soil, the other things are related to the seeds and fertilizers that are used for food production according to their season. So, to produce crops, we must deal with the soil moisture and the sunlight and the air quality needed for the crop's good health [14]. So, for this purpose, this project can measure all the basic conditions of the soil for the healthy growth of our crop using IoT-based sensors like moisture and temperature sensor for soil and the air quality checking the gas sensor is required with the measurement of the intensity of sunlight required we use a luminosity sensor. So, with the help of this project, we can easily analyze and improve the way of our crop production. This project will help the farmers to increase the rate of output of food produced and helps the farmer to make an unceasing exercise all over the world [14]. Moving towards the detail of the sensors that we use in this project are temperature, moisture, gas, fire, and luminosity sensor. The moisture sensor will show us the level of moisture in the sand in accordance with its reading; the water pump motor will operate as the required level of the moisture of sand that is suitable for the health of crops or plants is less than the motor will operate until the required condition is fulfilled, the gas sensor basically shows the reading of the gases like carbon dioxide, nitrogen etc. that are essential for the good health of our crop present in the air, the luminosity sensor shows the amount of sun light that is important for the plant or crop production and the flame or fire sensor is used in case of fire- flames it will show the reading of the presence of fire in our mobile app. This project, Digital Twin Technology in Smart Farming, advances the field's monitoring system that could collect and examine the data. Anyhow the selection and steps were taken by the farmer himself. The project can be extended to vast applications, but we are using limited applications.

### 1.3 Project Objectives:

This project aims to build, design and implement a portable and cost-effective IoT-based smart agriculture system that is made specifically for monitoring, a mobile phone-based smart application and for predicting and storing the data as a cloud-based service. In addition, these sensors play an important role in giving the reading through the raspberry-pie module to the smart application mobile app so the farmer can take immediate action according to the readings provided on the app through sensors if the threshold is exceeded for the proper growth of his crop. There are several objectives that are needed to be done in order to achieve our required goal successfully. These are stated below as followings:

- To design an efficient system that can notify the farmer before any fatal condition that is not suitable for the good health of its crop.
- To reduce the un-healthy conditions for the growth of the crop.
- To provide a real-time monitoring system of the crop.
- To establish the accurate prediction of the data collected through sensors.
- To establish better management of fields and crop using new technologies.
- To provide the farmer proper control of the field through smart mobile-phone applications.

## 1.4 Project Scope:

As for the scope of the project, digital twin technology can advance smart farming in the most amazing ways. Smart agriculture is dealing with the enablers to produce more food for the increasing population worldwide. Smart agriculture can provide more efficient ways to use natural resources for the production of food and to improve land and environmental management. Digital Twin Technology in Smart farming plays an important part in all players in the supply chain by empowering the well-organized and fair flow of data and, in doing so, easing well decision-making. Digital Twin Technology in Smart farming helps farmers to well recognize the major elements such as water, aspect, vegetation, and soil types. This project will help the farmers to decide on a better way of using natural resources for the healthy production of crops. It will also help farmers to monitor and do changes according to the increase or decrease in threshold values for the healthy production of their crops. So, these IoT-based sensors connected to the raspberry-pie provide the essential readings of the land and environmental aspects. This data is stored on cloud server and can be monitored through the smart mobile-phone application. So, it will help the farmer to act accordingly after checking the readings through an app and can take measurements accordingly. So, this Digital Twin Technology in Smart farming will provide us with up-to-date and real-time data through the cloud and predicted maintenance and scheduling of the field or crops.

# Chapter 2

## Literature Review

## 2.1 History of Digital Twin

The aerospace and defence sectors are where the idea of digital twin technology initially emerged to simulate intricate systems and procedures. Yet, the concept of creating a digital model of a physical system has been around since the middle of the twentieth century. In the early days of digital twin technology, it was used primarily in the aerospace and defense industries to model complex systems, such as aircraft and missiles. This technology was used to simulate the behavior of these systems and to analyze their performance, and it was instrumental in helping engineers and designers to improve their performance and reliability. Over time, digital twin technology has evolved and expanded into other industries, including manufacturing, healthcare, and energy. Today, digital twin technology is used to model and analyze a wide range of systems, from individual components to entire production facilities. The expansion of digital technologies like IoT and cloud computing, along with the growing data availability, are some of the key factors influencing the development of digital twin technology. As a result of the real-time collection and analysis of enormous amounts of data made possible by these technologies, more advanced and precise digital twin models have been created. Another factor contributing to the growth of digital twin technology is the increasing demand for predictive maintenance and real-time decision-making. By using digital twin technology to model and analyze complex systems, organizations can gain a deeper understanding of their behavior and performance and use this information to make more informed and timely decisions. One of the main challenges facing digital twin technology is ensuring that the digital representations of physical systems are accurate and reliable. This requires the integration of multiple data sources and using sophisticated algorithms to model and



analyze system behavior. Another challenge facing digital twin technology is data management and privacy concerns. With the increasing amounts of data being generated and collected, it is important to ensure that this data is secure and protected from unauthorized access and breaches. In conclusion, digital twin technology has a long and rich history and has evolved into a powerful technology used in many industries. Despite its growth and success, there are still many challenges facing digital twin technology. It will be important for organizations to address these challenges to ensure their continued growth and success.

## **2.2 Purpose of this technology**

Digital twin technology's goal is to provide organizations with a flexible virtual image of a physical object that may be utilized for various tasks. This technology has the potential to revolutionize the way organizations operate and make decisions by providing real-time data and insights into the behavior and performance of physical entities. One of the key purposes of digital twin technology is monitoring and analysis. With the help of digital twins, organizations can track the performance and behavior of physical objects in real-time and get valuable data and insight for analysis. For example, a digital twin of a manufacturing facility could be used to monitor the performance of equipment and machines, providing data on utilization, efficiency, and energy consumption. This data can be used to optimize operations, improve performance, and reduce costs. Another purpose of digital twin technology is simulation and testing. Digital twins also simulate physical entities' behavior under various conditions, allowing organizations to test and evaluate designs, prototypes, and systems before they are built or deployed. This can help organizations identify potential

issues and make improvements, reducing the risk of failure and increasing the likelihood of success. For example, a digital twin of a building could be used to test and evaluate the performance of HVAC systems, lighting, and other building systems, allowing organizations to optimize these systems for energy efficiency and comfort. Predictive maintenance is another key purpose of digital twin technology. Digital twins also anticipate possible issues with physical objects, enabling companies to take proactive measures to solve issues before they arise and save downtime. For example, a digital twin of a wind turbine could be used to monitor the performance of the turbine and predict potential issues with the gearbox, generator, or other components, allowing organizations to schedule maintenance and avoid costly downtime. Optimization is another important purpose of digital twin technology. Digital twins can optimize the efficiency and performance of physical entities by analyzing data, testing different scenarios, and making improvements based on real-time feedback. For example, a digital twin of a shipping fleet could optimize routes, reduce fuel consumption, and improve delivery times. Finally, digital twin technology can be used to support decision-making. By providing organizations with real-time data and insights, digital twins can help organizations to make more informed decisions and improve their operations. For example, a digital twin of a city could be used to support decision-making around transportation, energy, and other critical infrastructure. In conclusion, the purpose of digital twin technology is to provide organizations with a virtual image of a physical object that can be used for various purposes, including monitoring, analysis, simulation, testing, predictive maintenance, optimization, and decision-making. This technology has the potential to revolutionize the way organizations operate and make decisions, providing real-time data and insights that can be used to improve performance, reduce costs, and

increase efficiency.

## 2.3 Benefits of using Digital Twin Technology

Digital twin technology has several benefits that make it a valuable tool for organizations across a range of industries. Some of the key benefits of using digital twin technology include the following:

1. **Improved decision-making:** Digital twin technology provides organizations with a wealth of data and insights into the behavior and performance of physical entities, such as products, systems, and infrastructure. This information can support decision-making, allowing organizations to make informed decisions based on real-time data and analytics. For example, digital twin technology may use to optimize energy consumption, reduce costs, and improve product quality.
2. **Increased efficiency:** Digital twin technology allows organizations to simulate the behavior and performance of physical entities in real-time, providing valuable insights into how they function. This information can be used to optimize operations, reduce waste, and increase efficiency. For example, digital twin technology can improve supply chain management, reducing stockout risk and increasing delivery schedules' accuracy.
3. **Improved safety:** With digital twin technology, it is possible to track the behaviour and performance of physical objects in real-time, providing early warning of potential safety issues. This can improve safety and reduce the risk of accidents, making it an essential tool for organizations that operate in hazardous environments, such as manufacturing facilities or offshore oil rigs.

4. Predictive maintenance: Digital twin technology allows organizations to monitor the performance of physical entities in real-time, providing early warning of potential maintenance issues. This can improve the accuracy of predictive maintenance, reducing equipment failure risk and maximizing the assets' lifespan.
5. Enhanced product development: Digital twin technology allows organizations to simulate the behavior and performance of new products before they are manufactured, providing valuable insights into their functionality and performance. This information can be used to improve the design of products, reducing the risk of defects and improving the overall quality of the final product.
6. Cost savings: Digital twin technology can help organizations reduce costs by optimizing operations, reducing the risk of equipment failure, and improving the accuracy of predictive maintenance. Additionally, the ability to simulate the behavior and performance of physical entities in real-time can help organizations reduce the need for physical prototypes, saving time and money in the product development process.
7. Better customer experience: Digital twin technology is used to monitor and analyze the behavior and performance of physical entities, providing valuable insights into how customers use them. This information can be used to improve the customer experience, for example, by providing real-time support and addressing customer issues more quickly.
8. Improved sustainability: Digital twin technology can be used to monitor and optimize energy consumption, reducing the impact of physi-

cal entities on the environment. Additionally, the ability to simulate the behavior and performance of physical entities in real-time can help organizations reduce the need for physical prototypes, reducing waste and improving sustainability.

## **2.4 Basic design concept of Digital Twin**

A digital twin's primary design principle is to develop a digital view of a physical entity, such as a system, infrastructure, or product. In order to provide organizations with valuable data and insights into the behavior and performance of the physical entity, the digital twin's goal is to closely mimic its behavior and attributes. This can support decision-making, optimize operations, and improve performance. A digital twin is typically created using a combination of digital technologies, including sensors, software, and data analytic. Data from the physical object is gathered using sensors and transmitted to a software platform to create the digital twin. Depending on the application's needs, the sensors can be installed either within or externally to the physical object. Typically, the software platform used to create the digital twin is built on Internet of Things (IoT) technology, which allows organizations to gather, store, and analyze massive volumes of data in real-time. The platform should be scalable and flexible, allowing organizations to easily add or remove sensors as needed and be secure to ensure that the data collected is protected. Data analytics is a critical component of the digital twin, as it allows organizations to extract insights and knowledge from the data collected by the sensors. This can support decision-making, improve performance, and optimize operations. For example, data analytics can be used to identify patterns and trends in the data, such as changes in energy consumption or usage patterns, which can

optimize energy efficiency and reduce costs. The data analytics should be user-friendly, allowing organizations to easily access and interpret the data, and should be integrated with the software platform to provide real-time insights. The graphical user interface (GUI) is another important component of the digital twin, as it allows organizations to visualize and interact with the digital twin. The GUI should be intuitive and user-friendly, allowing organizations to easily access and interpret the data. The GUI should provide a visual representation of the digital twin, including information on the behavior and performance of the physical entity, as well as any insights or recommendations generated by the data analytic. The design of the digital twin should also consider the physical entity's requirements. For example, the sensors used to collect data from the physical entity may need to be rugged and durable if the physical entity is located in a harsh environment, such as an offshore oil rig or a manufacturing facility. The software platform should also handle large amounts of data in real-time. It should integrate with other systems, such as manufacturing execution systems (MES) or enterprise resource planning (ERP) systems. In addition to the technical requirements, the design of the digital twin should also consider the organization's business requirements. For example, the digital twin may need to support multiple languages or comply with data privacy regulations. The digital twin should also be easy to implement and use, with a low total cost of ownership, to ensure that organizations are able to quickly realize the benefits of the technology. Finally, the design of the digital twin should also consider the organization's future needs. The digital twin should be scalable and flexible, allowing organizations to easily add or remove sensors as needed, and it should be able to evolve over time as the organization's needs change. This will ensure that the digital twin remains relevant and valuable over the long term.

## 2.5 Enabling Digital Twin Technology

Enabling digital twin technology involves several key steps, including:

1. **Data collection:** The first step in enabling digital twin technology is to collect data from physical entities, such as products, systems, and infrastructure. This data can be collected from sensors, telemetry, and other sources and must be accurate, complete, and up-to-date. To ensure data quality, organizations must clearly understand the data sources, how they will be used, and the data management processes that will be required. In addition, organizations must have the right infrastructure in place to store and manage the data, such as cloud-based storage, data lakes, and data warehouses.
2. **Data integration:** Once data has been collected, it must be integrated with other data sources, such as historical data, simulation models, and operational data. This integration must be performed in a way that ensures data accuracy, completeness, and consistency. To achieve this, organizations must have a well-defined data integration strategy, which includes using data integration tools and data governance processes. In addition, organizations must ensure that the data integration process is secure and that data privacy is protected at all times.
3. **Data visualization:** Data must be visualized in a form that makes it easy to understand, analyze, and interpret. This can be achieved through the use of interactive dashboards, real-time data visualizations, and other data analysis tools. The visualizations must be designed to be intuitive and accessible to all stakeholders, regardless of their technical expertise. In addition, organizations must have the

right infrastructure in place to support data visualization, such as cloud-based data analytics platforms and visualization tools.

4. Model creation: The next step is to create a digital twin model that accurately represents the physical entity. This model must be based on data collected from the physical entity and data from other sources, such as simulation models and historical data. The model must be designed to be flexible and scalable, allowing it to evolve over time as new data and insights are generated. In addition, the model must be validated and tested to ensure that it accurately represents the physical entity and that it provides reliable results.
5. Simulation and analysis: Once the digital twin model has been created, it can be used to simulate the behavior and performance of the physical entity. This simulation must be performed in real-time, allowing organizations to monitor the performance of the physical entity in real-time and make informed decisions based on the data and insights generated. To achieve this, organizations must have the right infrastructure in place to support simulation and analysis, such as cloud-based computing platforms and high-performance computing systems.
6. Continuous improvement: Finally, the digital twin must be continuously improved over time based on new data and insights from the physical entity. This continuous improvement cycle ensures that the digital twin remains accurate and up-to-date, providing organizations with a valuable tool for monitoring and optimizing the behavior and performance of physical entities. To achieve this, organizations must have a well-defined continuous improvement process in place, which includes regular review and updates of the digital twin model, da-



ta collection and integration processes, data visualization tools, and simulation and analysis methods.

## **2.6 Challenges required for implantation of a digital twin?**

Implementing digital twin technology is a complex process, and there are several challenges that organizations must overcome in order to realize its full potential. Some of these challenges include:

1. **Data quality:** The data used to create and maintain the digital twin model is critical to its accuracy and usefulness. Data must be accurate, complete, and up-to-date, and organizations must clearly understand the data sources and how they will be used. In addition, data integration must be performed to ensure data accuracy, completeness, and consistency.
2. **Data security and privacy:** One major challenge is to guarantee the privacy and security of the data utilized in the digital twin model. Data storage and processing must be safe, and organizations must have a well-defined data security and privacy strategy in place. This strategy should include measures to protect data privacy, such as data encryption and access control, as well as measures to prevent data breaches, such as firewalls and intrusion detection systems.
3. **Integration with existing systems:** Digital twin technology must be integrated with existing systems, like customer relationship management (CRM) ERP systems and manufacturing execution systems (MES) are two examples. This integration must be performed to ensure data accuracy, completeness, and consistency, and organizations

must have the right infrastructure to support the integration process, such as cloud-based data integration platforms and APIs.

4. Data governance: A well-defined data governance mechanism is required to ensure the quality and reliability of the data utilized in the digital twin model. This process should include measures to ensure data accuracy, completeness, consistency, and data validation and verification processes. In addition, data governance should include a clear understanding of who has access to the data, how it can be used, and what measures are in place to prevent data breaches.
5. Technical expertise: Implementing digital twin technology requires a high level of technical expertise, including expertise in data collection and integration, data visualization, simulation and analysis, and continuous improvement. Organizations must have the right people in place to support the implementation process, including data scientists, data engineers, and software developers, and the right tools and systems to support their work.
6. Change management: Implementing digital twin technology requires significant change management, as it involves changes to existing systems, processes, and organizational structures. Organizations must have a clear awareness of how these changes will affect them and their stakeholders and a well-defined change management process to manage the transition. This process should include measures to educate stakeholders about the benefits of digital twin technology and address any resistance to change.
7. Cost: Implementing digital twin technology can be expensive, and organizations must have a clear understanding of the costs involved,

including the cost of data collection and integration, data visualization, simulation and analysis, and continuous improvement. Organizations must also have a clear understanding of the return on investment (ROI) they can expect from the technology and must have a well-defined budget in place to support the implementation process.

8. Technical limitations: Digital twin technology is still in its early stages of development, and technical limitations must be overcome to realize its full potential. For example, the technology is still developing regarding the accuracy and realism of the models, the speed of simulation, and the ability to integrate data from multiple sources.

## 2.7 Digital twin in the agriculture sector

The application of digital twin technology in farming has the potential to alter how farmers run their businesses and increase yields. By building a digital representation of a real-world agricultural system, farmers may utilise data and simulation to optimise their operations, monitor performance, and arrive at well-informed choices.

1. Precision Agriculture: Precision agricultural assistance is one of the main advantages of digital twin technology in agriculture. A management technique called precision agriculture employs data and technology to streamline farming processes, increase yields, and save expenses. In order to build a complete picture of the farm, digital twins in agriculture can gather and analyse data from numerous sources, including sensors, drones, and satellite photos. Using this knowledge, decisions about planting, watering, fertilising, and pest control can be made with confidence.

2. **Real-time Monitoring:** Digital twin technology also enables real-time monitoring of agricultural operations. This allows farmers to monitor the health of their crops and livestock, track weather patterns, and manage resources in real-time. For example, digital twins can be used to track the moisture levels of crops, the growth rate of livestock, and the quality of the soil. This information can be used to make informed decisions about watering, feeding, and other management practices.
3. **Predictive Analytics:** Another benefit of digital twin technology in agriculture is its ability to support predictive analytics. Predictive analytics is a technique that uses data and machine learning algorithms to predict future events. In agriculture, predictive analytics can predict crop yields, forecast weather patterns, and optimize resource allocation. For example, digital twins can be used to track the moisture levels of crops, livestock growth rate, and soil quality. This information can be used to make informed decisions about watering, feeding, and other management practices.
4. **Sustainability:** Digital twin technology can also support sustainability in agriculture. By monitoring the impact of farming operations on the environment, digital twins can help farmers make informed decisions about resource use, minimize waste, and reduce their carbon footprint. For example, digital twins can be used to monitor water and fertilizer use, track greenhouse gas emissions, and identify opportunities to conserve resources.
5. **Collaboration and Decision-making:** Digital twin technology also enables agricultural collaboration and decision-making. By sharing data and information in real-time, farmers, agronomists, and other stakeholders can work together to make informed decisions about resource

allocation, production processes, and risk management. Digital twins can also be used to facilitate communication and collaboration between different departments within an organization, such as marketing, supply chain, and operations.

## **2.8 Iot based smart agriculture monitoring system vs digital twin smart agriculture monitoring system**

IoT-based smart agriculture monitoring systems and digital twin-based smart agriculture monitoring systems are two of the most promising technologies in the field of agriculture. Both are designed to help farmers optimize their operations and improve yields, but they differ in several key ways. IoT-based smart agriculture monitoring systems are based on a network of sensors and devices that collect data about crops, soil, weather, and other factors. This data is transmitted to a central hub where it can be analyzed and acted upon. The key advantage of IoT-based systems is their ability to provide real-time data on crop and soil conditions, which may assist farmers in making prompt choices regarding watering, fertilizing, and pest control. For instance, soil moisture sensors could be positioned across the field to keep track of the soil's moisture levels. This data can determine when to water the crops, which can help conserve water and reduce the risk of drought stress. Weather sensors can also be used to collect temperature, rainfall, and wind speed data, which can help farmers make decisions about crop protection and disease management. However, IoT-based systems have some limitations. For one, they typically use simple data analytics techniques, such as statistical analysis and regression, to make predictions and identify patterns. Their predictive capabilities

are limited, and their results can be imprecise. Additionally, IoT-based systems can be less expensive to implement. Still, they may require additional human intervention to make decisions, which can be time-consuming and lead to human error. In contrast, digital twin-based smart agriculture monitoring systems rely on a digital representation of the real-world agricultural system, which can be fed by a range of data sources, including IoT devices, satellite imagery, and weather forecasts. This digital representation, or “digital twin,” allows farmers to simulate various scenarios and make more informed decisions about their operations. The key advantage of digital twin-based systems is their ability to use data from a range of sources to create more accurate and sophisticated models of the real-world system. For example, satellite imagery can be used to monitor crop health and identify areas of the field that may require additional attention. This information can be combined with soil moisture and weather sensor data to create a more complete picture of the agricultural system. In turn, this information can be used to make more informed decisions about crop management, such as adjusting the timing of fertilization or pest control treatments. Digital twin-based systems can leverage advanced machine learning algorithms and predictive analytics to make predictions and identify patterns. This means they can provide farmers with more accurate and sophisticated recommendations, helping them make better decisions and optimize their operations. Additionally, digital twin-based systems can automate decision-making and provide farmers with actionable recommendations based on the data and simulations generated by the digital twin. For instance, machine learning algorithms can analyze historical weather data and soil moisture levels to predict future crop yields. This information can be used to make decisions about planting dates, crop rotations, and the selection of seed varieties. Predictive analytics can also identify

the optimal time for fertilization and irrigation, which can help farmers conserve water, reduce the risk of disease, and increase yields. However, there are also some challenges associated with digital twin-based systems. For one, they can be more expensive to implement, as they require more advanced technology, such as high-performance computing, data storage, and machine learning algorithms. Moreover, developing and maintaining the digital twin itself and training the machine learning algorithms may involve a large time and resource investment for digital twin-based systems.

## **2.9 Limitation of this technology(Digital Twins)**

Digital twin technology, despite its numerous benefits, also faces some limitations that need to be addressed for its widespread adoption and implementation. Some of these limitations include the following:

1. **Cost and Complexity:** Digital twin technology can be costly to implement and maintain, as it requires high-performance computing, data storage, and machine learning algorithms. The cost of the underlying hardware and software required to run digital twin simulations can be substantial, and the ongoing costs associated with maintenance and updates can also be high. Furthermore, the process of creating and maintaining the digital twin itself can be difficult and time-consuming, requiring a significant investment of both time and resources.
2. **Data Management and Privacy Concerns:** Digital twin technology requires a significant quantity of data, which needs to be gathered, saved, and continuously analyzed. This data can include sensitive information such as personal data, trade secrets, and confidential business information. Ensuring this data is secure and protected from

unauthorized access and breaches is a major challenge that must be addressed to ensure the privacy and security of digital twin systems.

3. **Accuracy and Reliability:** Digital twins rely on complex algorithms and simulations to model real-world systems, which means that the accuracy and reliability of the digital twin can be affected by the quality and accuracy of the data used to create the model. In addition, the digital twin can only be as accurate as the data it is fed, which means that it is dependent on the quality and accuracy of the data sources used to create the model.
4. **Integration with Existing Systems:** Combining digital twin technology with current systems may be a difficult and time-consuming procedure since it needs the integration of numerous data sources and systems. This can be especially challenging in large organizations where multiple systems are in place and data is stored in different formats and locations. Ensuring that the digital twin integrates seamlessly with existing systems and that data can be easily shared and accessed is a key challenge that must be addressed.
5. **Data Analytics Capabilities:** Digital twin technology relies on data analytics and machine learning algorithms to make predictions and provide actionable recommendations. So far, both the quality and accuracy of the data used to train the algorithms and the algorithms themselves may impact the dependability and accuracy of these predictions. Ensuring that the data analytics capabilities of digital twin systems are accurate and reliable is a major challenge that must be addressed.
6. **Model Validation and Verification:** Digital twin technology relies on



simulations to model real-world systems, which means that the accuracy and reliability of the digital twin can be affected by the accuracy and validity of the model itself. Ensuring that the digital twin model is accurate and validated against real-world data is a key challenge that must be addressed to ensure the accuracy and reliability of the digital twin.

7. Human Expertise: Digital twin technology can automate many decision-making processes, but it still requires human expertise and judgment in many cases. For example, digital twin simulations can provide recommendations about the best course of action, but it is up to human operators to make the final decision about how to act on these recommendations. Ensuring that human operators have the necessary expertise and judgment to make informed decisions is a key challenge that must be addressed.

# Chapter 3

## Requirement Specifications

This chapter thoroughly examines the current systems connected to our project. The detailed description and breakdown of each system component are then provided in this chapter.

### 3.1 Existing System

Many solutions were introduced to the problem of farm management systems or farm monitoring systems; the figure below shows that the researchers developed a fuzzy (prototype) system to comprehend this problem [1]. In this project, the system was incorporated by taking sensor input, deciphering it using probabilistic reasoning architecture, and employing the Internet of Things as the user interface. Since the project aims to assist farmers, a more straightforward system design is required without a sophisticated theoretical foundation. The correlation between the atmospheric temperature, moisture content, soil wetness, and watering time was thoroughly included in the system by making full use of the knowledge from fuzzy systems. In comparison to the manual and traditional farming tools, the method is, therefore, more effective. The chosen platform has translated the information into the IoT.

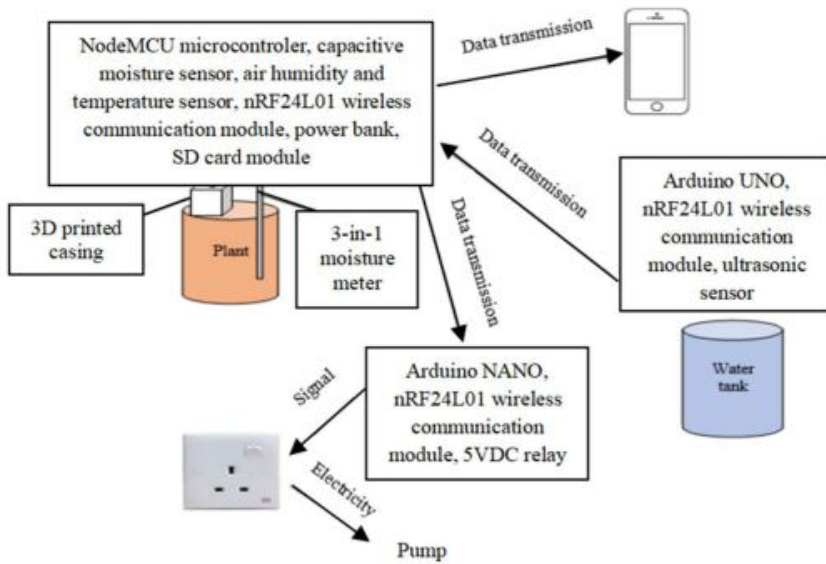

Figure 3.1: Existing subsystem layout [1]

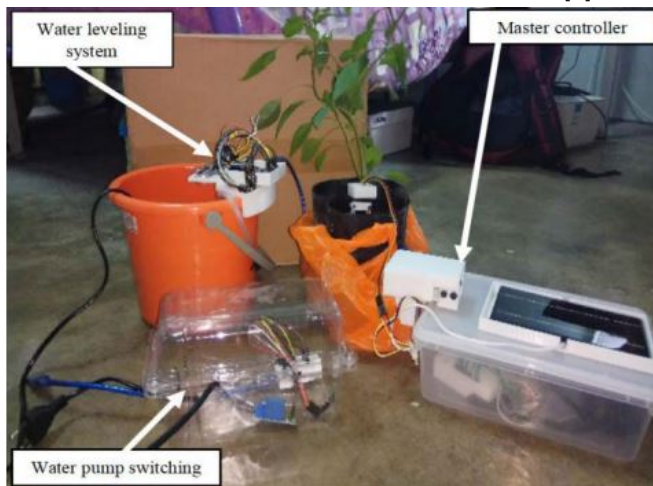

Figure 3.2: Existing system prototype [1]

## 3.2 Proposed System

The proposed system or more dignified solution to the problem will not only be just monitored by using IoT sensors as explained above, but we will also perform model prediction, 3d model visualization and metric analysis of our system as well. The system will use a four-level supervised machine learning method to compute and estimate the field for the appropriate climate in phenomena as,

1. **Data:** Data sets on soil properties, climatic conditions, and seed quality are used to forecast harvests and boost agricultural yields.
2. **Data Pre-processing:** This parameter is essential if we have any missing data values from the data set.
3. **Extraction of Features:** To characterize a large data collection, the required data size would be reduced through feature extraction. The features that have a higher correlation value are chosen as a key predictive function for yield in this method, which bases its feature selection on the correlation matrix.
4. **Data training And ML model:** the final step is to split the data set into train, and test sets to train the model and develop a model best fit for the system.

### 3.3 System Requirements(Hardware Spec)

The table below shows the requirements and basic information regarding the smart digital system or IoT-based digital farm in which the main module(raspberry pi) monitors all the values using sensors attached to it and logs all the data from the sensor to Cloud Service.

<b>Raspberry Pi 4</b>
<b>Moisture Sensor YL-100</b>
<b>Gas Sensor MQ-135</b>
<b>DHT-22 Temperature and Humidity Sensor</b>
<b>Flame Sensor</b>
<b>LDR Sensor</b>
<b>ADS 1115(ADC)</b>
<b>Monitor(Display),Inputs(Keyboard,Mouse)</b>
<b>Relay Switches</b>
<b>Motor or pump (general outdoor operation)</b>

Table 3.1: Digital Farm Components

**Our System can also be summarized as follows:**

- Acquiring Dataset, which consists of sensor data. And need to apply ML algorithms for training, testing and model prediction.
- Sensors connected to raspberry pi to measure data in real-time and send data to cloud agent.
- An app or application consisting of different input parameters for data visualization and observing any changes.
- A relay switch connected to raspberry pi for any automatic ON/OFF Operation, such as water pumping to a field or plant when desired parameter or condition is met.

### 3.3.1 RBPi 4(Raspberry Pi)

The RBPi 4 Model B is the most recent version of the well-known RBPi range of computers. It offers radically improved CPU speed, multimedia performance, memory, and connection over the RBPi 3 Model B+ of the previous generation while keeping backward compatibility and consuming roughly the same amount of power. For the user, the RBPi 4 Model B's desktop performance is comparable to that of entry-level x86 PC systems [2]. The main purpose for using raspberry pi instead of micro controller is



Figure 3.3: Raspberry Pi 4 [2]

because raspberry pi uses python language and is mainly used for Machine Learning algorithms so it is better to use raspberry pi instead of micro-controller.

**Raspberry Pi Specs and Features :**



<b>Computer:</b>	Quad-core Cortex-A72 (ARM v8) 64-bit SoC, 1.5GHz, Broadcom BCM2711 processor.
<b>Memory:</b>	2GB low-power double data rate(LPDDR4)
<b>Connection:</b>	ac wireless LAN operating at 2.4 and 5.0 GHz, Gigabit Ethernet 2 × USB 3.0 ports USB 2.0 ports in two
<b>General Purpose I/O:</b>	40-pin Raspberry standard connections
<b>Audio And Video:</b>	a pair of micro HDMI ports for composite video and stereo audio
<b>Graphic Card:</b>	OpenGL ES 3.0 graphics
<b>SD card:</b>	Operating system loading on a Micro SD card and data storage
<b>Supply Input:</b>	5V DC through USB-C connector(min 3 Ampere)
<b>Operating temperature:</b>	0 to 50 Degree Celcius

Table 3.2: RBPi 4 Model Specs [2]

### 3.3.2 Moisture Sensor(YL-100)

To measure soil moisture, a moisture device is used. It computes the moisture content of the soil and calculates the volumetric amount of water existing therein [3].

#### Soil moisture Specs and Features :

- Operating Voltage: DC 3.3 to 5
- 15 mA operating current
- Digital output range: 0V to 5V
- LEDs are 0V to 5V signalling output, and power is used for analogue output.
- PCB Dimensions: Based on the LM393 design, 3.2 cm by 1.4 cm
- Easy to use with ordinary Digital/Analog ICs or microcontrollers
- Compact, reasonably priced, and easily reachable



(a) Moisture Sensor [3]

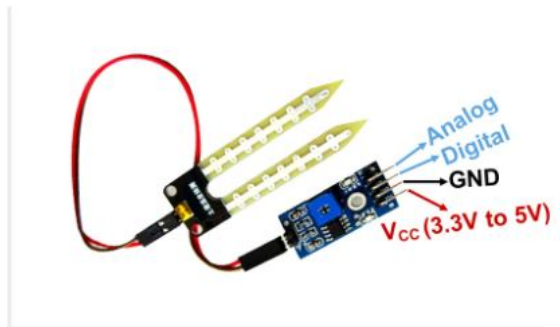

(b) Moisture Sensor Module [3]

Figure 3.4: Moisture Sensor Images [3]

The moisture sensor module is made up of resistors, capacitors, potentiometers, comparator LM393 ICs, Power LEDs, and Status LEDs. The voltage comparator in this moisture sensor module is an LM393 Comparator IC. The moisture sensor pin is connected to LM393 pin 3, while the preset pin is connected to LM393 pin 2. (10K Pot). The sensor pins threshold

<b>Voltage:</b>	5 volt
<b>Ground:</b>	Supply to Ground
<b>D0:</b>	Digital Output
<b>A0:</b>	Analog Output

Table 3.3: SM Pin Configuration [3]

voltage will be compared to the preset voltage set via pin 2 by the comparator IC [3]. The moisture sensor, which gauges the amount of moisture in the soil, is made up of two probes. These probes' immersion gold coatings prevent the nickel's oxidation by protecting it. The sensor analyses the resistance to determine the moisture values.

The mq135 sensor is generally employed in air pollution control systems and is suitable for detecting or measuring Ammonia, NO, NO<sub>2</sub>, Ethanol, Benzoic acid, Charcoal, and CO<sub>2</sub> [4].

### Gas Sensor Specs and Features :

- Broad detection range
- High sensitivity and quick response
- durable and long-lasting
- +5V is the operating voltage.
- NH<sub>3</sub>, NO<sub>x</sub>, alcohol, benzene, smoke, CO<sub>2</sub>, etc., can all be detected and measured.
- Analogue Output : 0 to 5 Volt
- Digital Output : 0 or 5 Volt (TTL Logic)
- 20-second reheating period
- Suitable for use as either a digital or analogue sensor

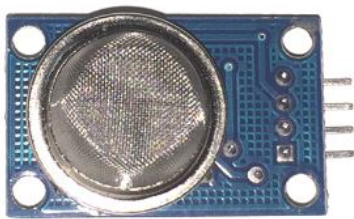

(a) Gas Sensor Module [4]

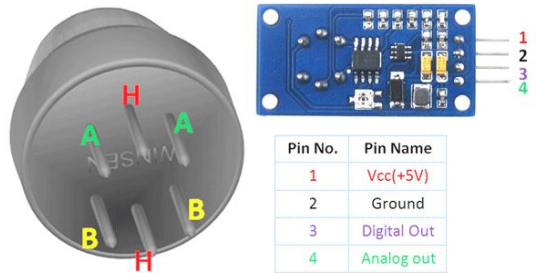

(b) Gas Sensor Pin configuration [4]

Figure 3.5: Gas Sensor(MQ-135) Images [4]

For module		
1	<b>Voltage:</b>	5 Volt
2	<b>Ground:</b>	Supply To Ground
3	<b>Digital Out:</b>	Outputs Digital Value
4	<b>Analog Out:</b>	Outputs Analog Value
For Sensor Pins		
1	<b>Pins(H):</b>	One pin is connected to the supply, and the other pin is connected to ground
2	<b>Pins(A):</b>	These pins will be linked to the voltage supply.
3	<b>Pins(B):</b>	The output pin will be one, and the ground pin will be the other

Table 3.4: GS-mq135 Pin Configuration [4]

### 3.3.3 DHT22 Temperature And Humidity Sensor

The DHT22 is a hybrid sensor. The sensor produces a calibrated digital signal that measures temperature and humidity. Due to its great sensitivity, the DHT-22 temperature and humidity sensor is used to measure temperature and humidity. and provides values that are generally accurate. It can accurately measure temperatures between -40 and 80 degrees Celsius. The sensor has NTC temperature measurement components and resistive sensing of wet parts.

#### DHT-22 Sensor Specs and Features :

- Voltage Range: 3.5 to 5.5V
- current: 0.3 mA
- Data output in serial
- Range of temperatures: -40°C to 80°C
- Range of humidity: 0% to 100%
- Pixel density: Both are 16-bit values.
- Precision: 0.5°C and 1%

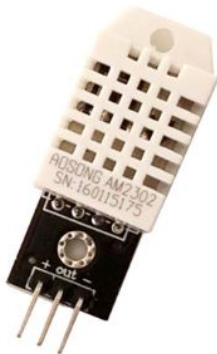

(a) DHT-22 Sensor Module [5]

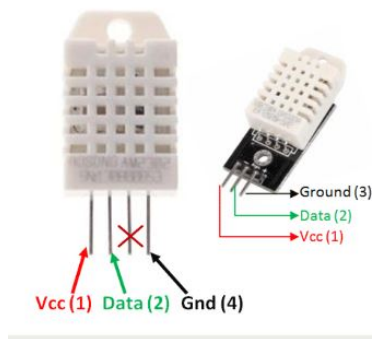

(b) DHT-22 Sensor Pin [5]

Figure 3.6: DHT-22 Sensor Images [5]

Module Pins		
1	<b>Voltage:</b>	Supply Range 3.5 to 5.5 volt
2	<b>DATA:</b>	Serial Data Output
3	<b>Ground:</b>	Connected to ground
Sensor(Pins)		
1	<b>Voltage:</b>	Supply Range 3.5 to 5.5 volt
2	<b>DATA:</b>	Serial Data Output
3	<b>N/C:</b>	Not Connected
4	<b>Ground:</b>	Connected to ground

Table 3.5: DHT22 Pin Configuration [5]

### 3.3.4 Flame Detector

To detect or respond to the presence of a fire or flame, a flame sensor is utilized.

#### Features and Specs:

- Operating voltage: 4.75 – 5V
- Working current: 20 mA
- light in a range 760nm to 1100nm wavelength
- Detection range: 0-1 m

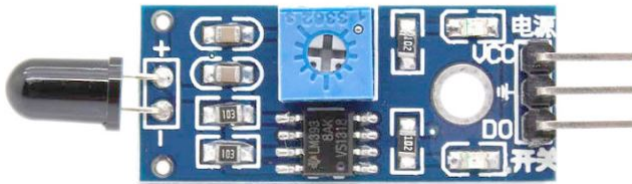

Figure 3.7: Flame Sensor Module [6]

1	<b>Voltage:</b>	Supply range 3.5 to 5.5 volt
2	<b>DO:</b>	Digital Output (0 or 1)
3	<b>Ground:</b>	Connected to ground

Table 3.6: Flame Detector Pin Configuration [11]



### 3.3.5 Luminosity Sensor

Detecting and measuring light intensity is possible with the low-cost digital and analogue sensor module known as LDR. This sensor is additionally referred to as a photo resistor sensor. An internal LDR (Light Dependent Resistor) aids in the detection of light by this sensor.

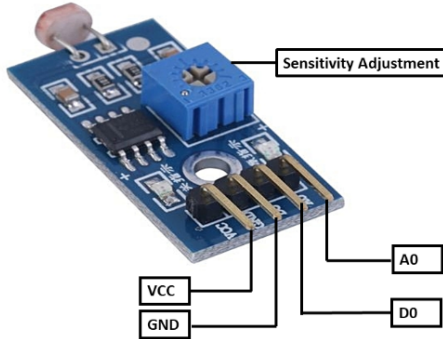

Figure 3.8: Luminosity Sensor Module [7]

1	<b>Voltage:</b>	Supply Voltage to 5.0 volt
2	<b>D0:</b>	Digital Output (0 or 1)
3	<b>Ground:</b>	Connected to ground
4	<b>A0:</b>	Analog Output Pin

Table 3.7: LDR Sensor Module Pin Configuration [7]

### **Advantages of LDR Sensor Module:**

- **Low Cost:** LDR sensors are relatively inexpensive and readily available, making them popular for many hobbyist and DIY projects.
- **Easy to Use:** LDR sensors are simple to use, requiring only a few lines of code to read the light level.
- **Versatile:** LDR sensors can detect light in a variety of wavelengths, making them suitable for a wide range of applications.
- **Energy Efficient:** LDR sensors consume very little power, making them an ideal for battery-powered devices.
- **Reliable:** LDR sensors are a proven technology that has been around for many years, and they have a long operational lifespan.

### **Disadvantages of LDR Sensor Module:**

- **Limited Accuracy:** LDR sensors are not very accurate and can be affected by factors such as temperature and humidity.
- **Slow Response Time:** LDR sensors have a slow response time compared to other types of light sensors, which may not be suitable for applications that require fast response times.
- **Limited Sensitivity:** LDR sensors may not be able to detect low levels of light or be sensitive enough for some applications.
- **Limited Dynamic Range:** LDR sensors have a limited dynamic range, which means they can only measure a certain range of light levels.
- **Susceptible to Interference:** LDR sensors can be susceptible to interference from other sources of light, which can affect their accuracy.

### 3.3.6 Analog-to-Digital Converter(ADS1115)

ADS1115 is a flexible Analog-to-Digital Conversion IC (ADC). This component is essential because the majority of sensors only produce analogue output, while the RBPi 4 requires digital input.

#### Features And Specs:

- Range of Operation:  $-40^{\circ}\text{C}$  to  $+125^{\circ}\text{C}$
- Range of Supply: 2 to 5.5 Volt
- 150 Ampere when Current Consumption is low or at continuous conversion
- Interface I2C: Four addresses selected by pin
- either two differential inputs or four single-ended inputs
- 8 to 860 samples per second (SPS) of programmable internal oscillator data rate

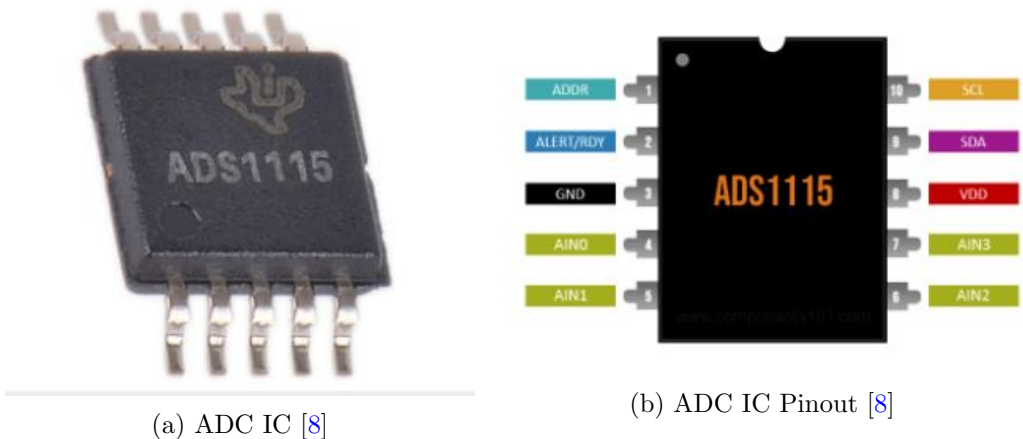

Figure 3.9: ADC(ADS1115) IC Images [8]

1	<b>Address:</b>	Address select
2	<b>Ready:</b>	Ready output from a digital comparator or conversion
3	<b>Ground:</b>	Connected to ground
4	<b>Analog in 0:</b>	Analog channel 1 input
5	<b>Analog in 1:</b>	Analog channel 2 input
6	<b>Analog in 2:</b>	Analog channel 3 input
7	<b>Analog in 3:</b>	Analog channel 4 input
8	<b>Voltage:</b>	Supply Voltage 2 to 5.5 volt
9	<b>Serial Data:</b>	T/R Data
10	<b>Serial Clock:</b>	Data clocks on the serial data pin

Table 3.8: ADS-1115 Pin Configuration [8]

### 3.3.7 Display And Inputs

Since we are using raspberry pi, we will be using a monitor for display. VGA monitor with vga cable will also need HDMI to VGA converter adapter to connect to the raspberry pi.



(a) Monitor [15]



(b) HDMI to VGA convertor [16]



(c) Power cable [17]



(d) KeyboardAndMouse [18]

Figure 3.10: Display and inputs

### 3.3.8 Relay Switch

The contacts of a switch are opened or closed by this electromechanical mechanism using an electric current. It is made up of parts that facilitate connection and switching.

#### Module Specs:

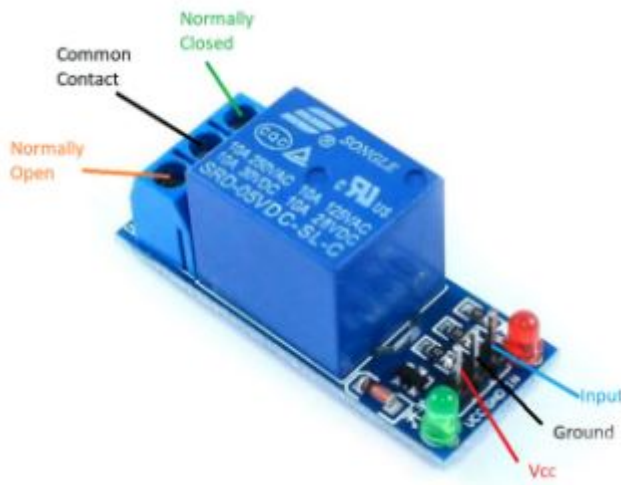

Figure 3.11: Relay Switch Module [9]

- Range of Voltage 3.75 to 6 Volt
- 2 milliamps of current
- 70mA of current flow when the relay is enabled.
- Relay Constant Voltage(MAX): 250 Alternate Current Voltage(ACV) or 30 Direct Current Voltage(DCV)
- Relay Current(MAX): 10 Amps

The principal parts of a relay module are as follows: 3 3-pin screw-type terminal connector, male header pins, 5V relay, transistor, diode, LEDs, resistors, etc. The relay's product number, "05VDC," indicates that the coil

1	<b>R Trigg.:</b>	A signal that triggers the relay
2	<b>VCC:</b>	Power Source of Relay
3	<b>GND:</b>	Ground
4	<b>Normally Open Contact:</b>	The relay's open terminal.
5	<b>Normally Closed Contact:</b>	The relay's closed terminal.
6	<b>Common Contact:</b>	The relay's Common terminal.

Table 3.9: Relay Switch Module Pin Configuration [9]

must be triggered at a minimum voltage of 5V in order to reliably close the contacts. Any voltage lower than this will not work. Additionally, there are marks for voltage and current that show voltage and current marks showing the maximum voltage and current that the relay can switch. When the relay is in operation, the "relay status LED" illuminates, showing the amount of current flowing through the relay coil. The relay coil is driven by the switching transistor switching transistor drives the relay coil by amplifying an input signal that cannot provide enough current to directly drive it drive it directly. This signal is then used to drive the relay coil. In this manner, a microcontroller or sensor output can drive the input. [9].

# Chapter 4

## System Design



The system architecture, design constraints, and system methodology of the comprehensive crop management or agricultural monitoring system are covered in this chapter.

## 4.1 System Architecture(Design Process/Procedure)

In this section, we are going to describe our system through different blocks, which is going to explain the whole system in a much easier way. Hence consequently, we have divided our system into three major portions, as shown in the block diagram.

- Farm/Field(Physical Environment)
- Cloud services Platform
- Digital Representation (Virtual Environment)

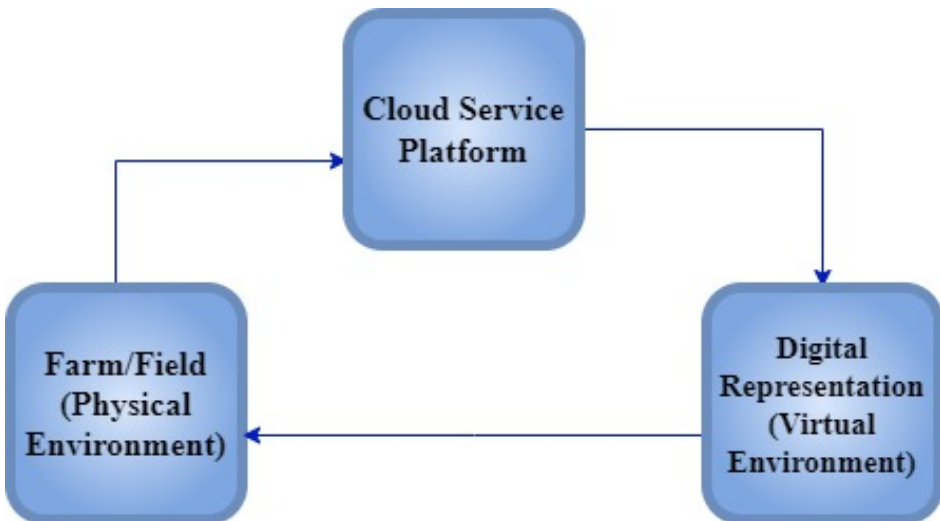

Figure 4.1: System basic Architecture

### 4.1.1 Farm/Field(Physical Environment)

In this block, the farm or field is the physical aspect/environment of our project. The Figure below shows a basic idea of our project, and it will be changed according to our budget constraints and requirements.



Figure 4.2: Project CAD design

The farm/field will have different IoT sensors which need to be configured to our raspberry pi module.

### 4.1.2 Cloud Service Platform

The second is cloud services which means that the data/information will be sent to IoT agents, and through that service, the data will be sent to cloud service storage and accessed through the service database in real time. We will use this service, a software platform that will be used to create IoT applications or consoles.

### 4.1.3 Digital Representation (Virtual Environment)

The final block element is essential to our project and defines our project outcome.

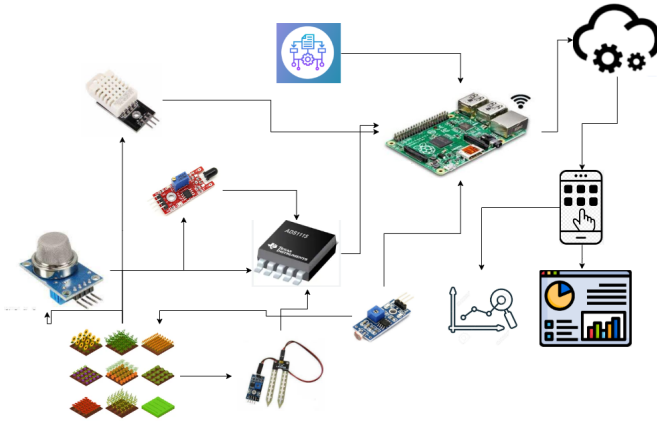

(a) System Software Design Logic

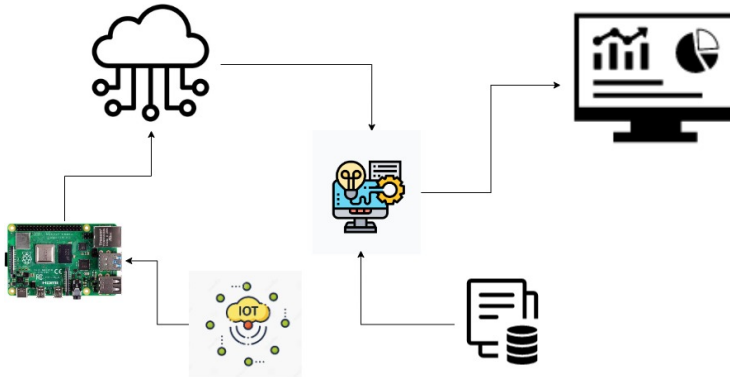

(b) System Software Design Logic

Figure 4.3: System Software overview [10]

In our previous system, we observed that the system works under the assumptions of a real-time based monitoring system and condition-based outcome. Thus we want to improve our outcome by applying the digital concept of 3d virtual-based visualization and metrics analysis.

## 4.2 Design Constraints

We have found the following limitations in our system:

- Since our device is IoT based, it merely depends on the WiFi signal strength for updating the values of moisture level, air quality, temperature and humidity, etc., on the Cloud server. So in case of a weak/No signal, it can go in a counter-negative way.
- Due to budget constraints and complexity, training of the system will be considered only those parameters in which the system is evaluated. For instance, if the parameters increase from 10 to 20. It becomes more difficult to observe and manage all systems at once. Thus this technology is better at minimum parameters observation.
- The module should stay switched on for all the sensors to work for their respective trained functions.
- This system does not work in the hazardous environment. If so, the system will not work properly, making it difficult to manage and predict outcomes.
- Even though we are designing our project to maintain the steady and stable outcome of our field without much or any supervision since it is just a prototype, minimum supervision should be considered; otherwise, it will lead to the critical condition of our field.

### 4.3 Design Methodology

We have designed this methodology by considering the previous systems that have been designed and implemented for monitoring temperature, Humidity and soil moisture in the soil field to control the sufficient water level within the time frame. The first thing that comes to mind is how we are going to implement all this using digital technology known as the Internet of Things and then how we can take immediate actions (such as alert SMS, manual operation, conditional operational etc.) in case of any Wi-Fi signals failure and emergency situation and how we can make an efficient monitoring system which can portray a smart living. Keeping all of the above concerns in mind, we are going to implement the following methodology to design an efficient and predictive base user-specific outcome monitoring and management system:

1. First, we will need to consider the physical environment in which the system will be implemented since this is just a prototype, we will consider only certain parts of the field/farm and observe data on that particular environment.
2. To achieve our goal, we will employ a variety of sensors, including a flame/LDR sensor, air sensor, indicator of soil moisture, and temperature and humidity sensors.
3. We will be configuring all the above sensors to the RB-Pi 4.
4. The data will be sent cloud service platform from raspberry pi to fire real-time data to our database.
5. We also need to apply decision-making using the ML algorithm, which will help to predict user-specific outcomes or previous data

record management.

6. Our system works on a metrics system for efficient monitoring and communication with in the machine.
7. Our Raspberry Module will have a relay switch to switch between desired operations (such as start water pumping, fan etc.) when a certain condition is met.

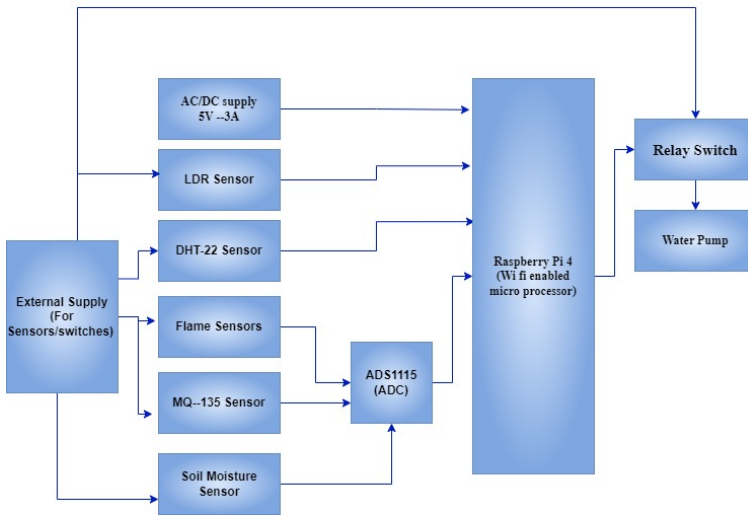

(a) System Hardware Design(Block Representation)

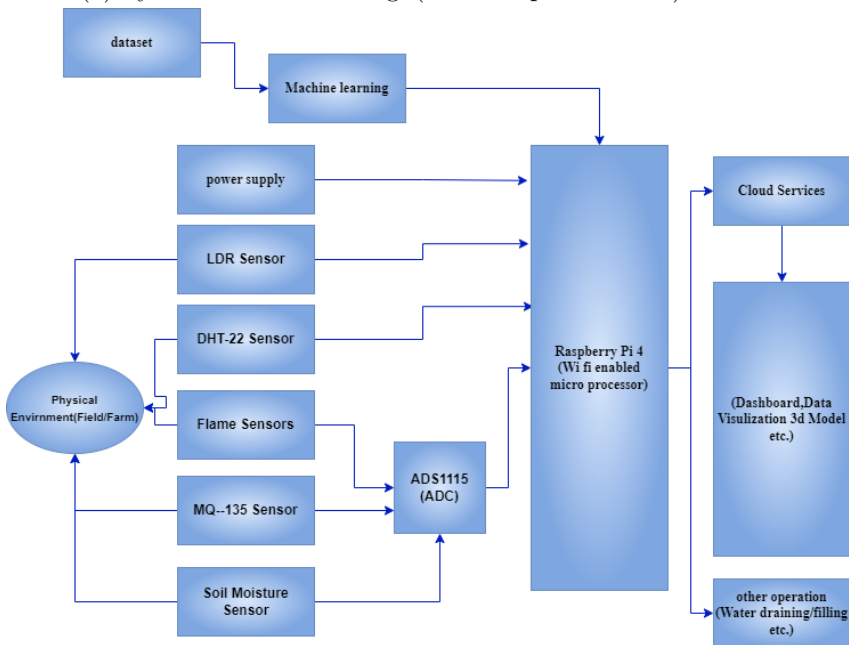

(b) System Design(Block Representation)

Figure 4.4: System Design Hardware And Software

# Chapter 5

## System Implementation



This chapter includes the block diagram of the system, which is implemented which is followed by the functional details of the hardware and the software implementation.

## 5.1 System Architecture(Implementation Process)

The figure below shows the system which will be implemented and observed in physical and digital environments.

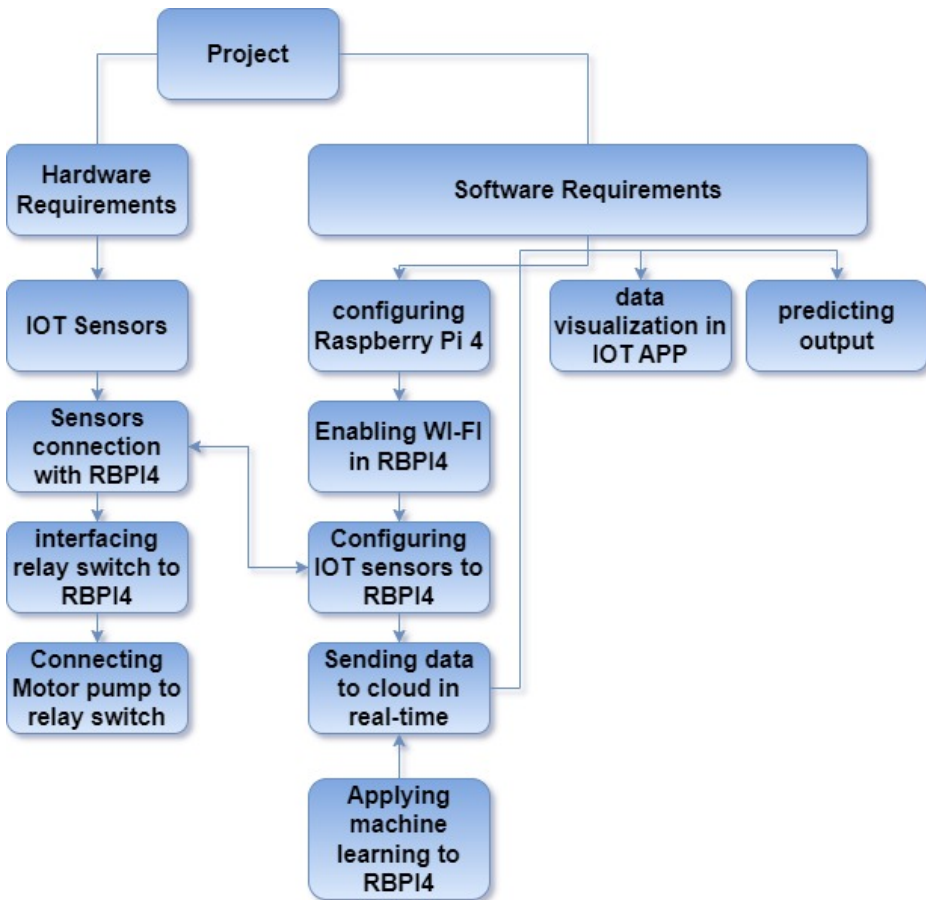

Figure 5.1: System Architecture(implementation)

## 5.2 Hardware Setup(Sensors Configuration And Coding)

In our project, we are using various Iot sensors for the monitoring of our field, such as a Gas sensor (MQ-135), Fire Sensor, Temperature sensor, Humidity sensor, LDR Sensor and Soil Moisture Sensor. All these sensors are interfaced with the GPIO pins of Raspberry Pi 4.

Since I have already explained all these sensors' specs and features etc. In this section, I will display real connected sensors to RBPI4.

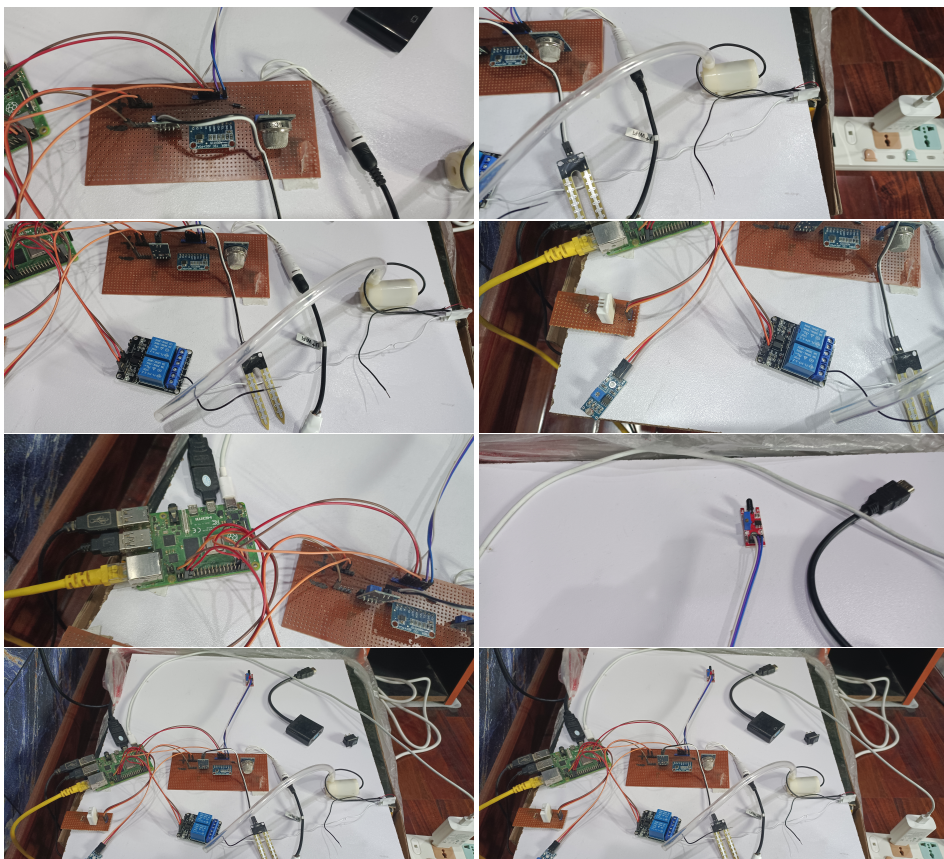

Figure 5.2: Sensors Interfacing

```

import RPi.GPIO as GPIO
import os
import board
import json
import random
import adafruit_dht
import Adafruit_ADS1x15
import numpy as np
import asyncio
from time import time, sleep

```

(a) Libraries Added

```

DELAY = 5
#PAYLOAD = '{"Soil_Moisture": {mois}}'
#telemetry_data = {'Temperature': temperatu
adc = Adafruit_ADS1x15.ADS1115()
GAIN = 1;
gpio=17;
GPIO.setwarnings(False)
GPIO.setmode(GPIO.BCM)
#Set Button and LED pins
pump=16;
ldr=19;
#Setup Button and LED
GPIO.setup(ldr,GPIO.IN)
GPIO.setup(pump,GPIO.OUT)
dhtDevice = adafruit_dht.DHT22(board.D4)

```

(b) Digital Sensor Coding

```

while True:
    if time() - SensorPrevSec > SensorInterval:
        SensorPrevSec = time()
        try:
            light = GPIO.input(ldr);
            value1 = adc.read_adc(0, gain=GAIN);
            value2=adc.read_adc(1,gain=GAIN);
            value3=adc.read_adc(3,gain=GAIN);
            air=(value1/32767)*100;
            mois=(value3/32767)*100;
            mois=abs(mois);
            air=abs(air);
            mois=100-mois;
            air=100-air;
            print("Moisture value",mois);
            print("Air quality value",air);

```

(c) Analog Sensor Coding

```

.....
temperature = dhtDevice.temperature;
humidity = dhtDevice.humidity;
print("Temperature=",temperature);
print("Humidity=",humidity);
print("Air_Quality=",air);
print("Flame_Detection=",a);
print("Soil_Moisture=",mois);
print("Light_Intensity=",light);
.....

```

(d) Displaying Output

Figure 5.3: Sensors Coding

**Note:** We use "Thoney IDE Python", an integrated build-in environment to develop our python programming/consoles. This Code is not a complete representation of our code running on our Pi. The Code will be further explained in Next Chapter afterwards. This Code shows/explains how the sensor's interfacing can be done.

## 5.3 Software Setup(Microsoft Azure Platform: Digital Twin)

The Software **Microsoft Azure** is a powerful cloud computing platform with dozens of features and services provided by it. The services we have considered in our project will be explained/observed afterward.

### 5.3.1 Azure Digital Twin

Microsoft Azure Digital Twins is a platform that allows you to create comprehensive digital models of physical environments. These models can be used to simulate, monitor, and control physical systems, such as buildings, factories, and cities. The platform provides a way to create a virtual representation of a physical environment, including all its components and their relationships, and then use this model to gain insights into how the system is functioning and optimize its performance.

Azure Digital Twins provides a range of tools for developers and engineers to build, test, and deploy digital models of physical environments. These tools include a range of APIs and SDKs for interacting with the platform and tools for visualizing and analyzing data from the digital model. The platform also provides a range of security features, including access control and encryption, to help keep your data safe and secure.

The image below shows our main digital twin instance, which we created using basic information. And after this, we created Azure Digital Twin Explorer Graph and 3d Scenes.

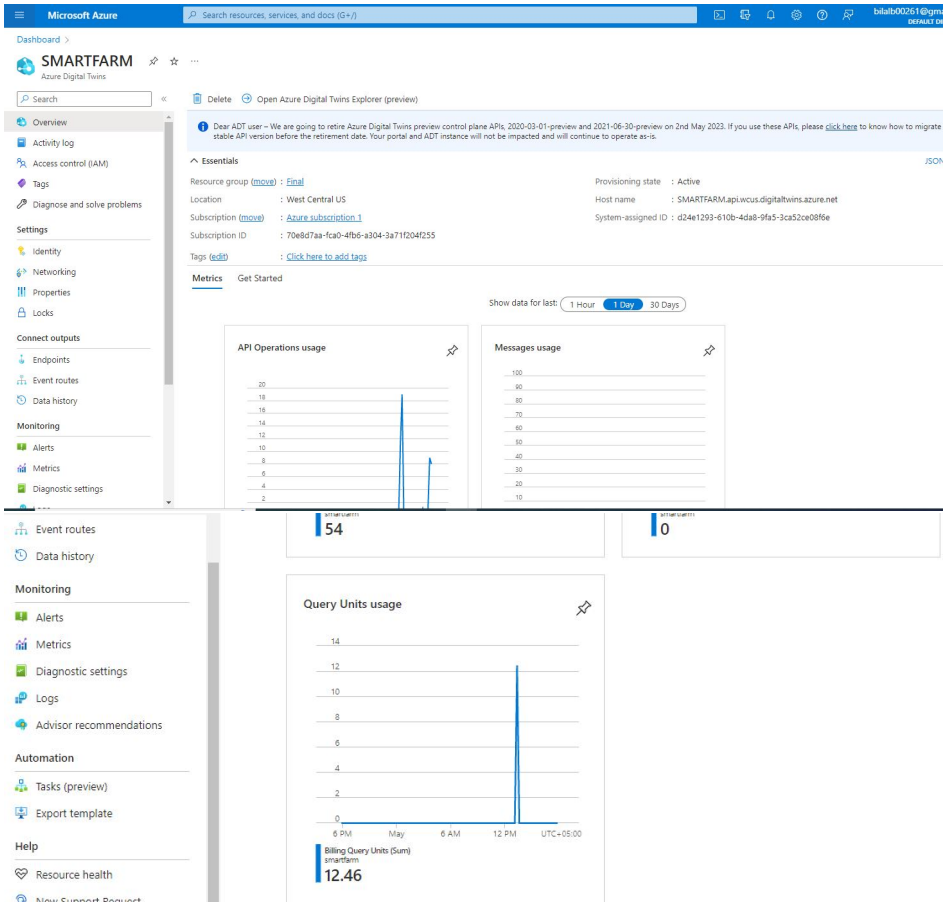
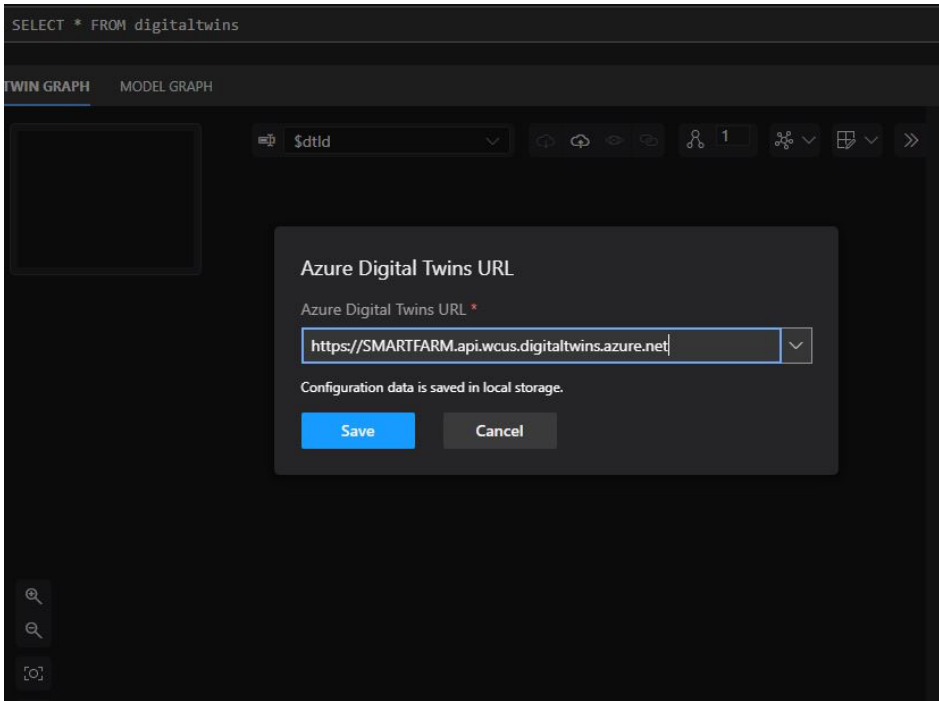

Figure 5.4: Azure Digital Twin Instance

### 5.3.2 Digital Twin Explorer

A digital "twin" of a real-world object, such as a machine or structure, is produced by the software program known as Digital Twin Explorer utilizing information gathered from sensors, cameras, and other sources. This virtual twin can be used to test changes or improvements without affecting the actual object and to simulate how the real object behaves under various circumstances.

**Note:** In Digital Twin Explorer, DTDL(.json) language models can be created in any programming development platform. After then, navigate to the "Models" tab and click "Upload Model". You will then be prompted to enter a name for your model, DTDL.



(a) Digital Twin instance link

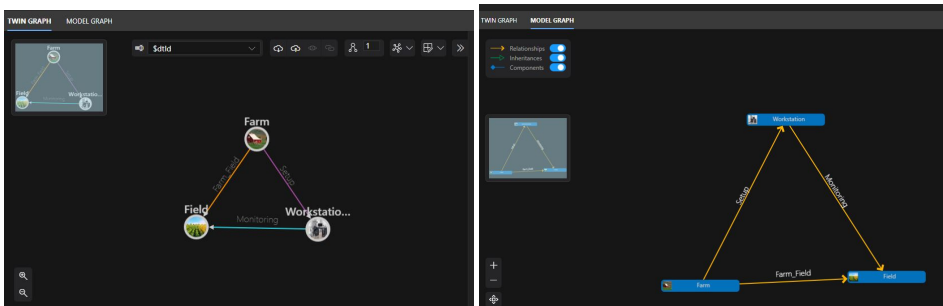

(b) Twin Graph

(c) Model Graph

Figure 5.5: Azure Digital Twin Explorer

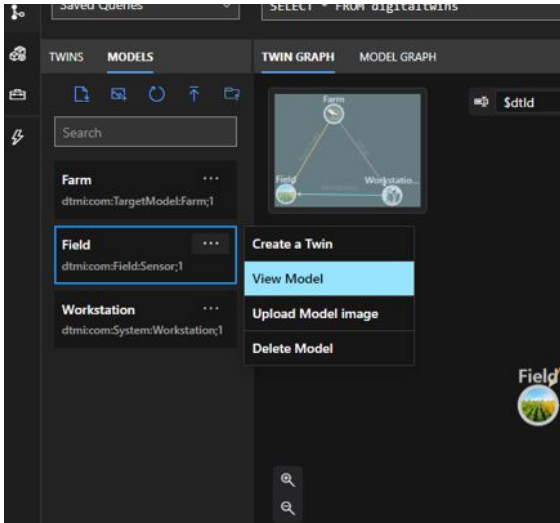

(a) View uploaded Model



(b) DTDL Language preview

Figure 5.6: Azure Digital Twin Explorer



### 5.3.3 Digital Twin Storage Account

Data can be kept in blobs, queues, and tables, among other types of storage containers, in a digital twin storage account. Depending on the requirements of the application, different types of data can be stored in these containers.

In this project, we used blobs to store large files, such as images, videos, and 3d Models.

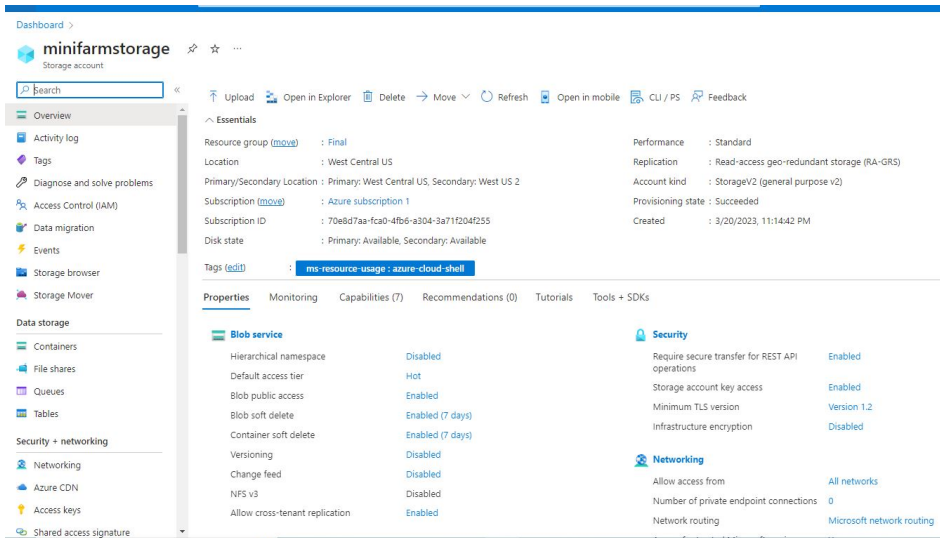

(a) Storage account

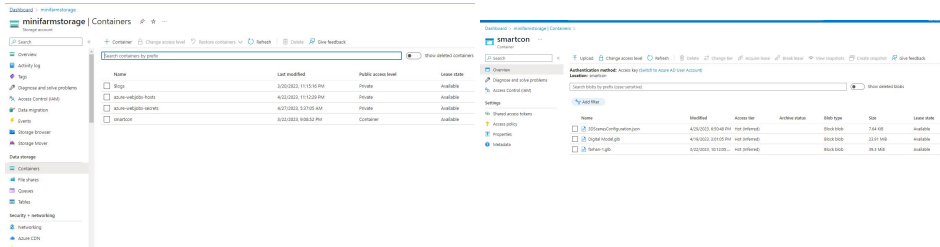

(b) Storage Containers

(c) Container files

Figure 5.7: Azure Digital Twin Storage

### 5.3.4 Digital Twin 3d Scenes( Virtual Model Representation)

Digital twin 3D scenes are virtual environments that are created to represent the physical world in a digital twin application. These scenes are often used in combination with sensor data and other real-time information to create a highly accurate and interactive representation of a physical asset or system.

In a digital twin 3D scene, the physical asset or system is modelled in a virtual environment using 3D modeling tools and techniques. This can include detailed models of individual components, as well as the surrounding environment and other contextual information.

**Note: We have created the model using software known as blender. Other software such as 3d engine, Unity, Autodesk, Forge, Revit, etc can also be used. But Azure only allows .glb or .glft format files to be uploaded in 3d scenes.**

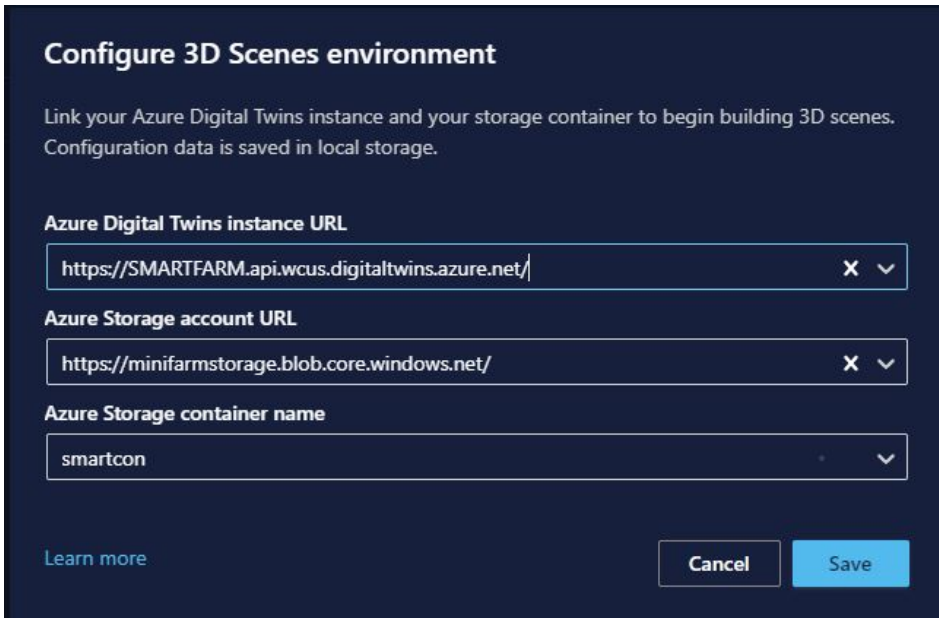

(a) Linking our 3d scene with account storage

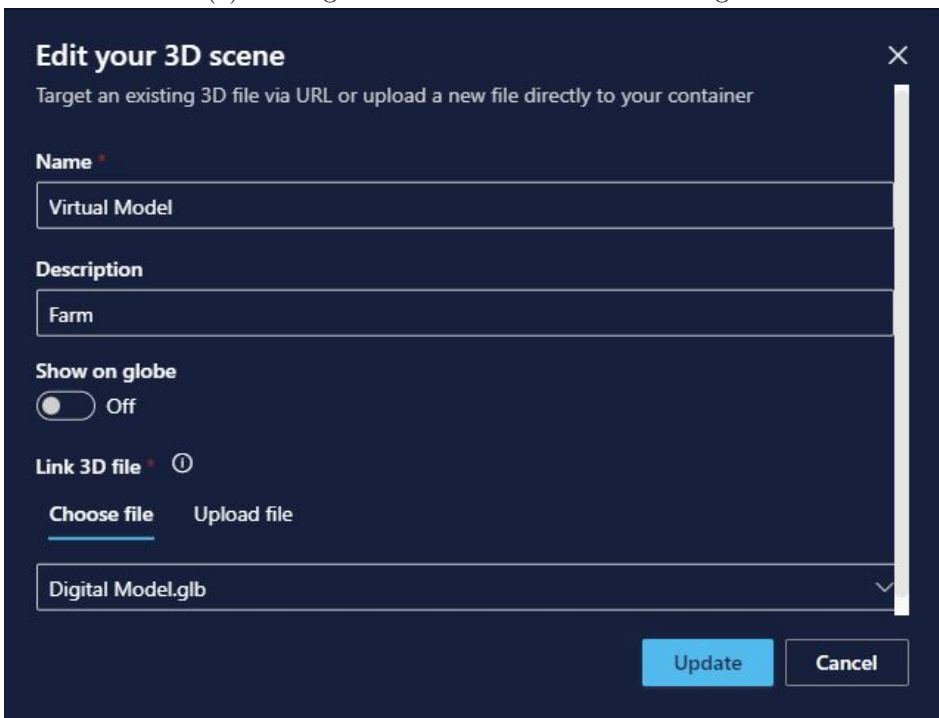

(b) Uploading Model to 3d scene

Figure 5.8: Azure Digital Twin 3d Scene

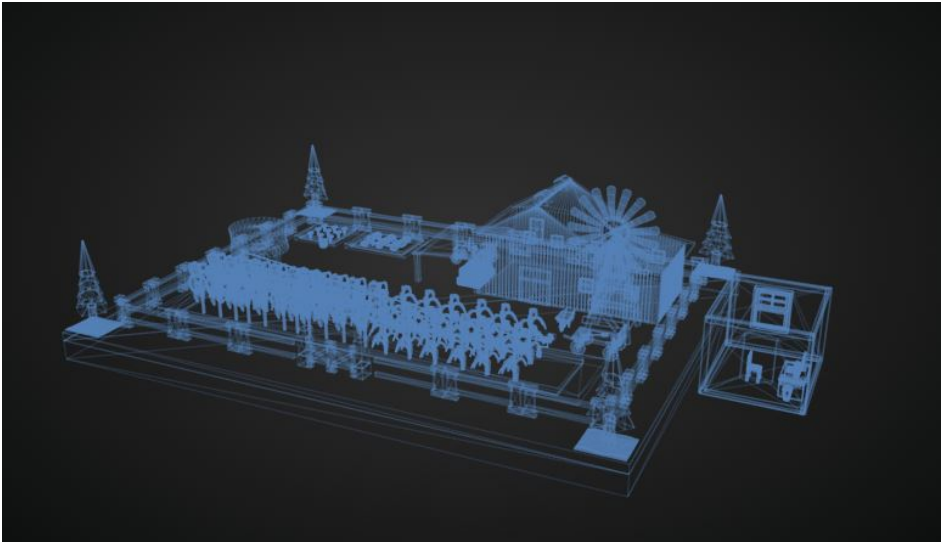

(a) 3d Model: Wirefram View

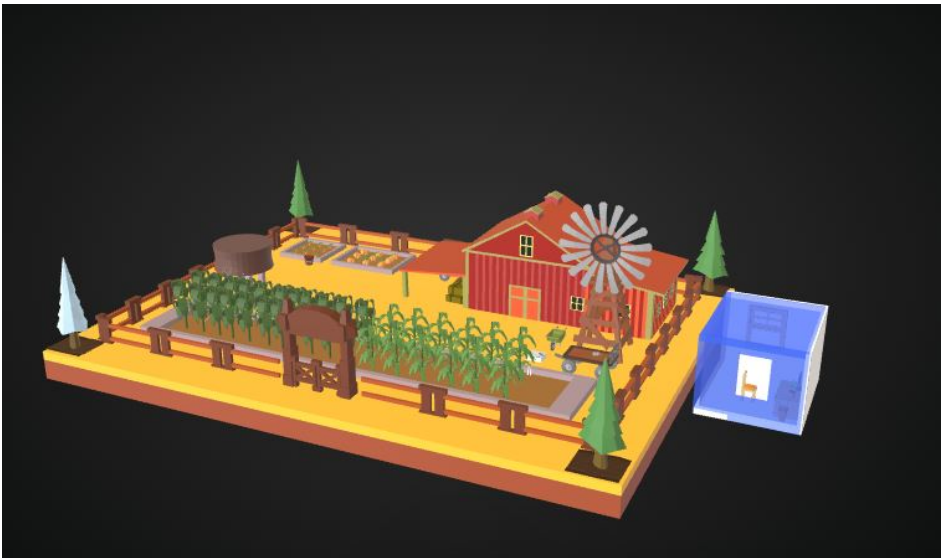

(b) 3d Model: Real View

Figure 5.9: Azure Digital Twin 3d Scene

### 5.3.5 Elements In 3d scene

Elements refer to the physical or virtual objects that are represented in a digital twin application. These can be individual components of a system or larger structures, such as buildings or factories. Other Factors are:-

1. Behavior: Behavior refers to the way in which elements interact with each other and their environment.
2. Twins: Twins are digital representations of physical assets or systems.
3. Visual rules: Visual rules specify the behavior of elements in a digital twin application. They allow developers to define conditions and actions based on data from sensors or other sources, enabling elements to interact with each other in a meaningful way.
4. Widgets: Widgets are user interface components that are used to display information and interact with a digital twin application.

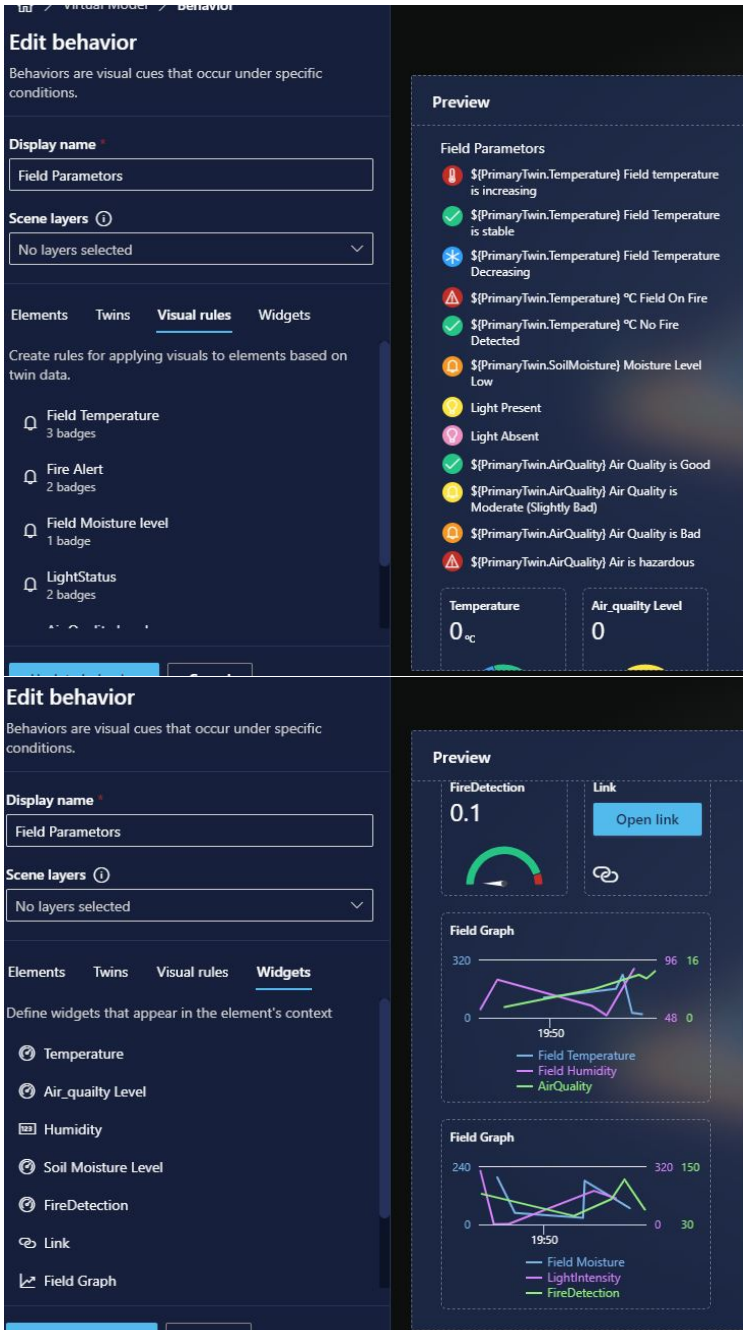
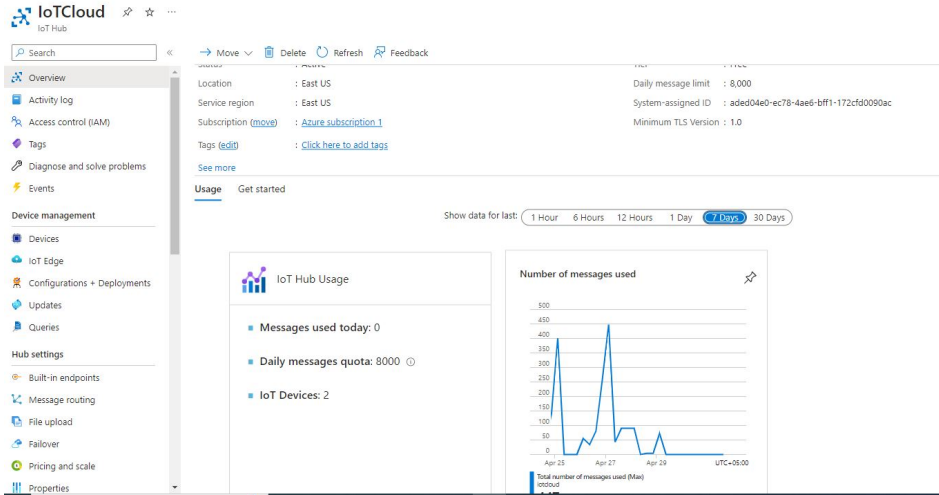

Figure 5.10: 3d Scene Elements Overview

### 5.3.6 Azure IOTHUB

As a fully managed cloud service, Azure IoT Hub offers a safe and scalable platform for integrating, managing, and connecting IoT devices. It provides bi-directional communication between IoT devices and back-end services and makes it simple for devices to connect to the cloud server.

- You can connect and manage IoT devices with Azure IoT Hub, regardless of their protocol or operating system.
- Azure IoT Hub offers a secure and scalable platform for connecting and managing IoT devices. Devices can be easily provisioned, configured, managed, and monitored for status and performance. IoT Hub lets you gather, store, and perform real-time IoT device data analysis.
- Before transmitting data to downstream services for additional analysis, you can modify and enrich it using built-in data processing tools. Enable two-way communication with Azure IoT Hub to enable real-time command and control scenarios. This allows you to send messages to IoT devices and receive messages from them.



(a) IOTHUB Service

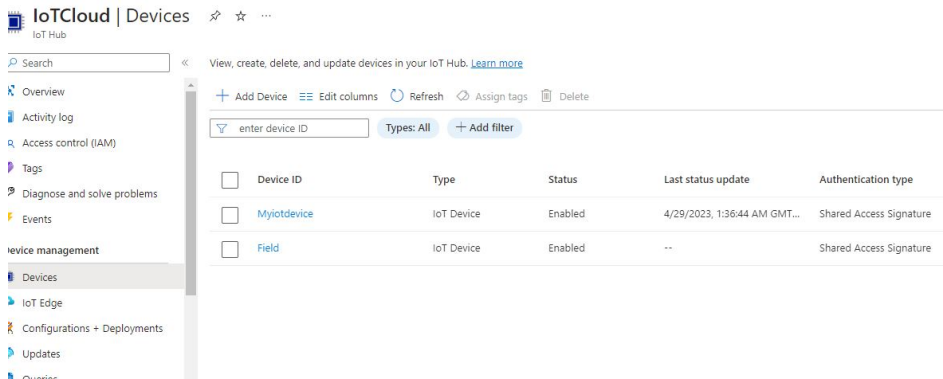

(b) IOTHUB Virtual Device Created

Figure 5.11: Azure IOT Cloud service



## 5.4 Event Hub And Clustering(Azure Data Explorer)

Event Hub provides a scalable and reliable platform for ingesting and processing large amounts of data. It can process millions of events per second and can be used to capture data from a variety of sources, including IoT devices, social media feeds, and application logs.

On the other hand, Azure Data Clustering is a data processing technique that groups similar data points into clusters based on their similarity. Clustering is a common technique used in machine learning and data analysis to identify patterns and relationships in data.

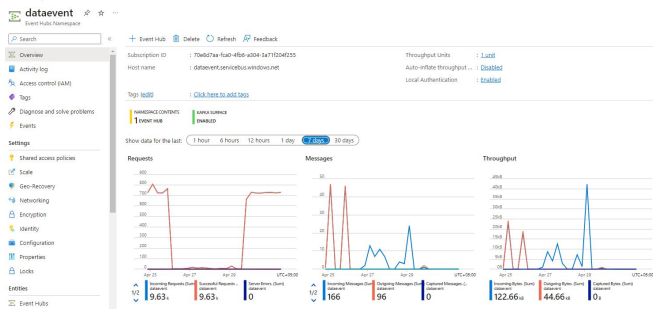

(a) Event-Hub Service

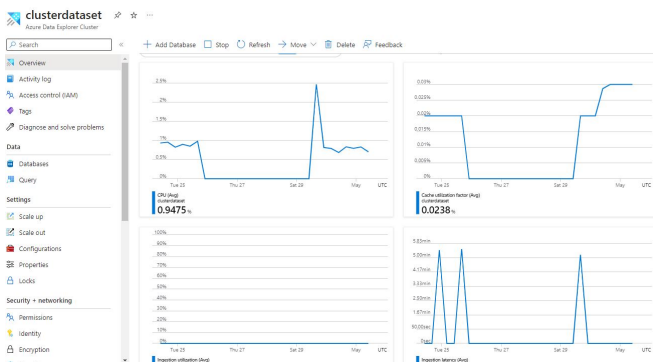

(b) Azure Data Explorer Service

Figure 5.12: Azure IOT Cloud service

### 5.4.1 Azure Function App

Azure Function Apps with Event Grid are often used in a variety of scenarios, such as processing IoT data, automating business workflows, and integrating with external systems. By using a serverless architecture, we can reduce costs and simplify deployment while still maintaining high levels of scalability and reliability.

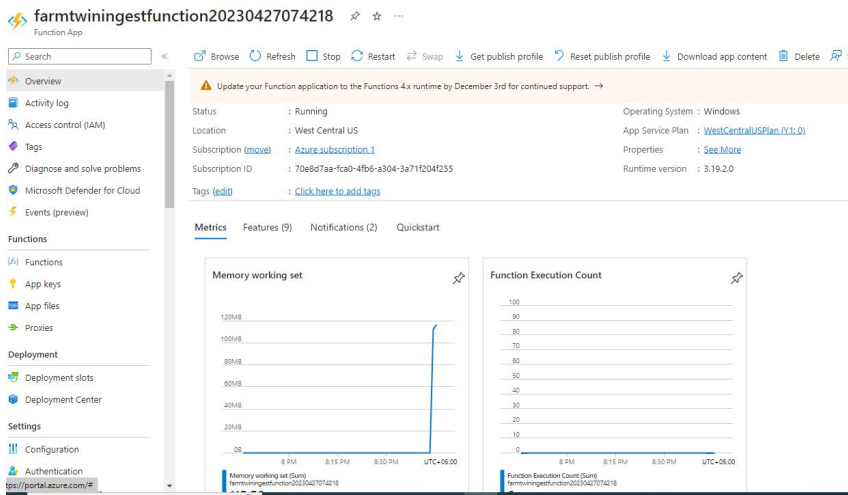

(a) Azure Function App

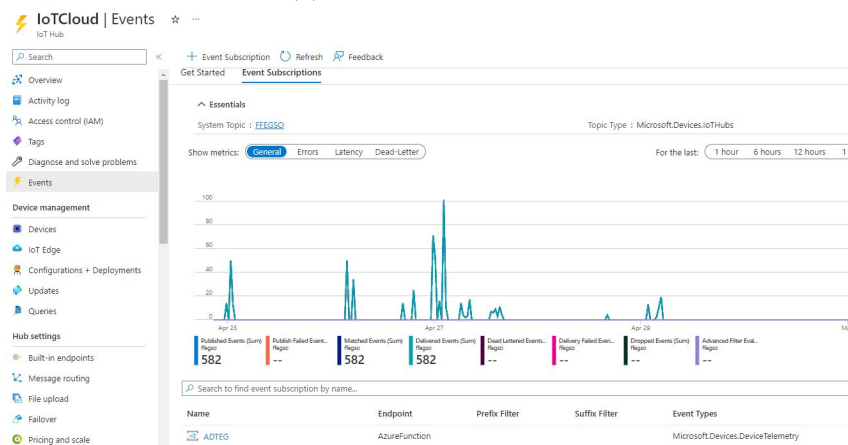

(b) Event Grid Trigger(Link to Function App)

Figure 5.13: Azure IOT ingest Function

## 5.5 Logic App

Logic Apps use a visual designer to create workflows comprising a series of steps or triggers executed in response to specific events or conditions. These steps can be simple actions like sending an email, or updating a database or more complex processes like parsing JSON data or integrating with an API.

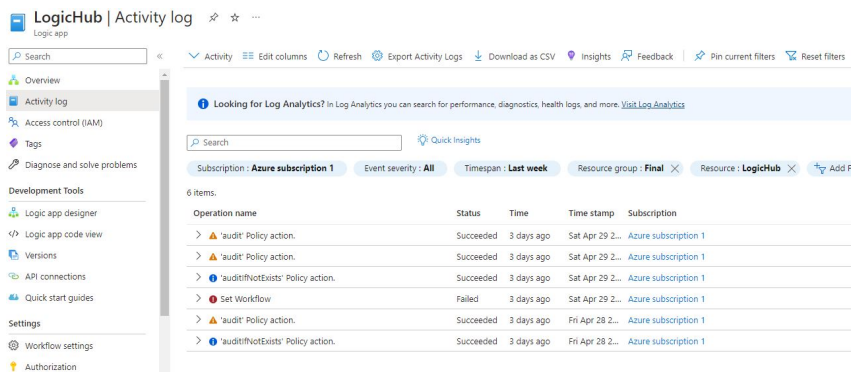

(a) Azure Logic App Service

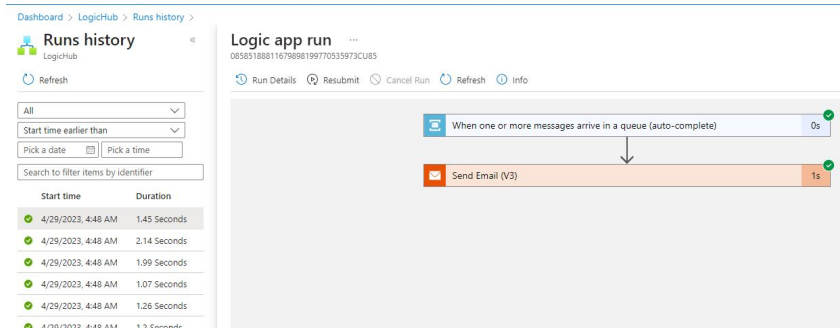

(b) Logic App Workflow(Link to Service Bus notifier)

Figure 5.14: Azure Notification Service

# Chapter 6

## System Testing and Evaluation

This Chapter list the Overview, Testing, Metrics Analysis and Outcome of our virtual-based 3d model, its back-end coding and other services overview.

## **6.1 Cloud Service Testing And Analysis**

Before viewing the 3d Model, we will see that the sensor data coming from RBPI4 is sent to IoT Hub service and then trigger the Event Function, which will also be monitored and check the telemetry (real-time sensor data) being fetched into our function to our 3d model.

And also send a notification to our user-end email server to notify us of any critical condition of our field.

Below shows an overview and results analysis of our system (pictorial representation).

### **6.1.1 Initial Analyses and Results**

Results of the system before system hardware(Hardware is disabled) is established.

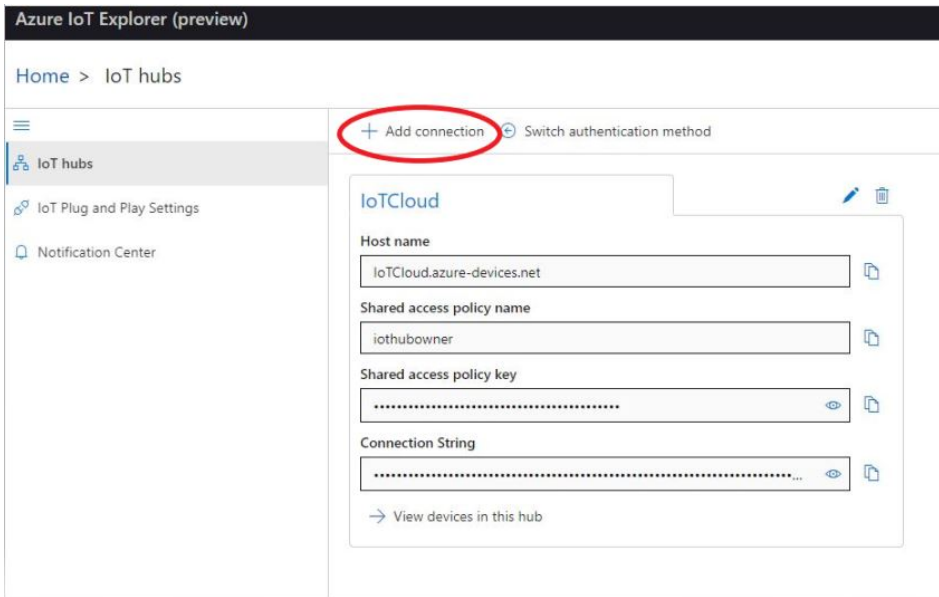

Figure 6.1: Adding Connection to Azure IoT Explorer to observe incoming telemetry

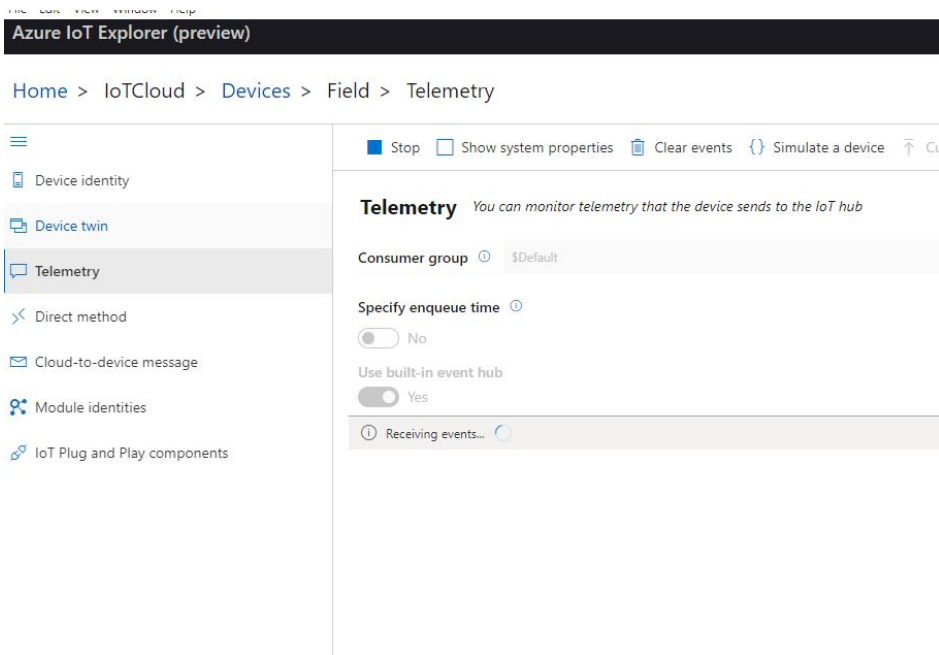

Figure 6.2: DeviceId:Field is used as a device to cloud server Azure IoT Explorer(No Message Read)

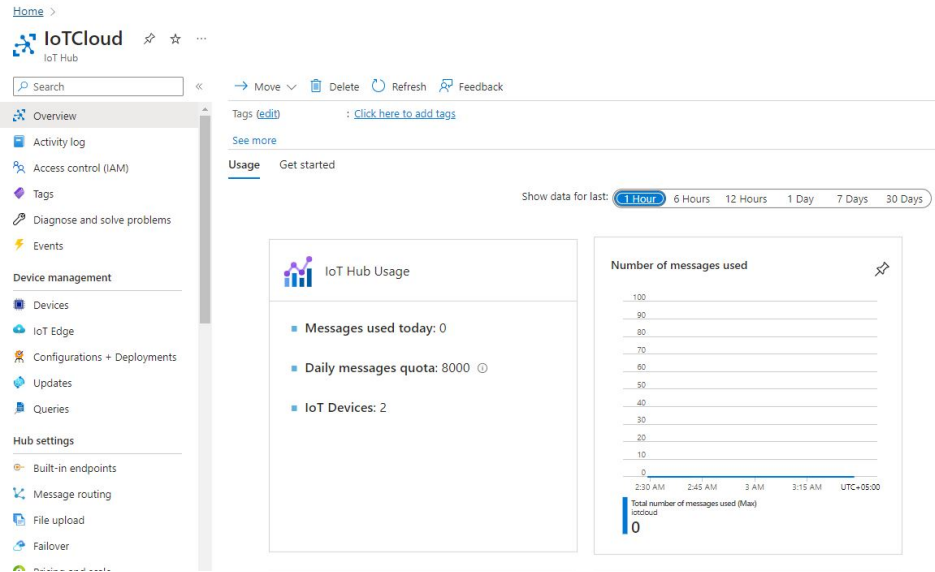

Figure 6.3: IOTHub Overview (No Message Read)

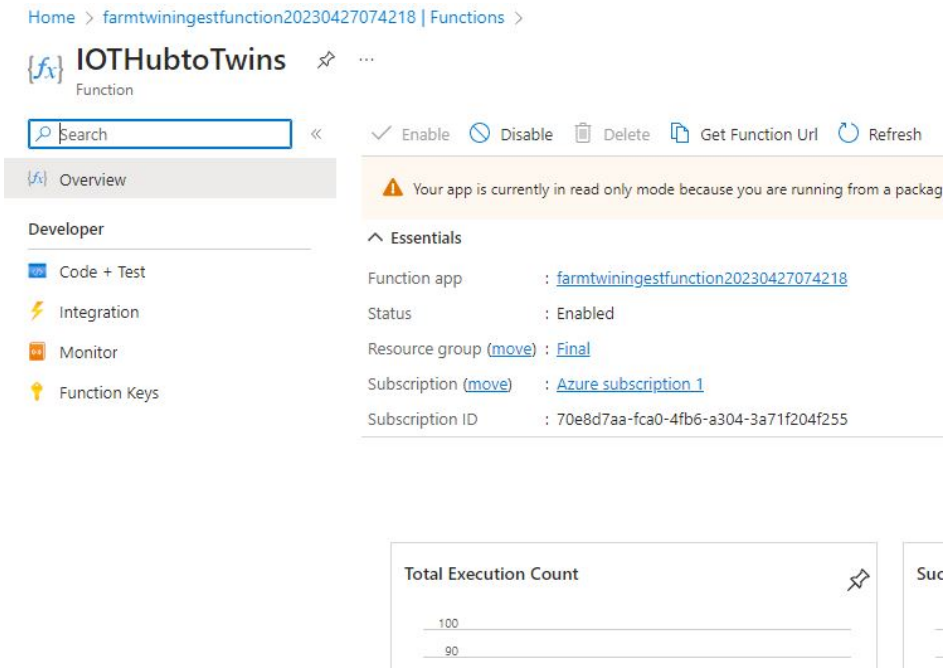

Figure 6.4: Azure Function App to transfer telemetry to Azure Explorer (No Message Read)

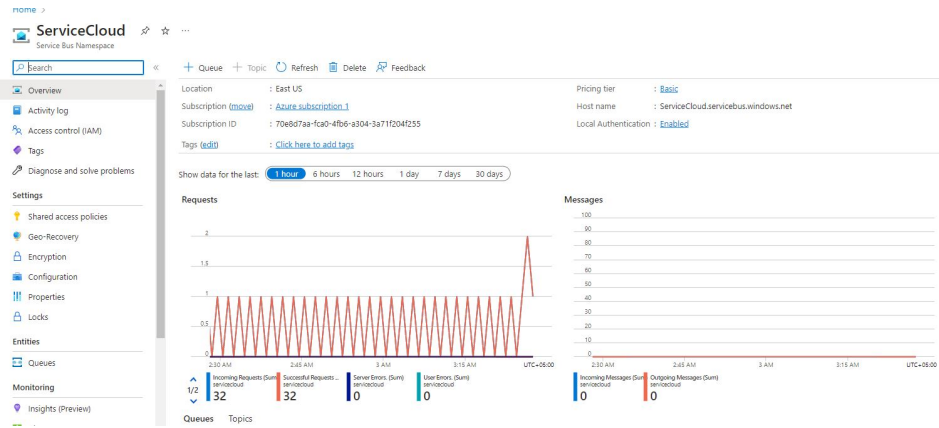

Figure 6.5: Service Bus Event Notifier Overview (No Messages Read)

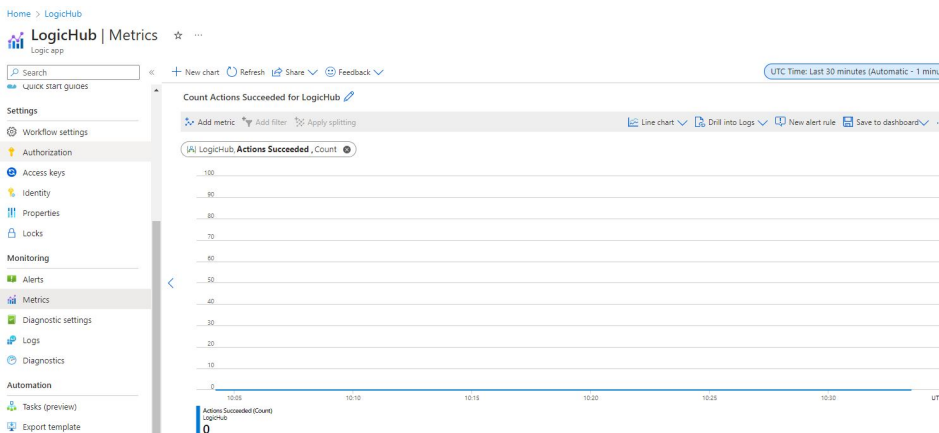

Figure 6.6: Logic Hub Metrics Overview (No Message Read)



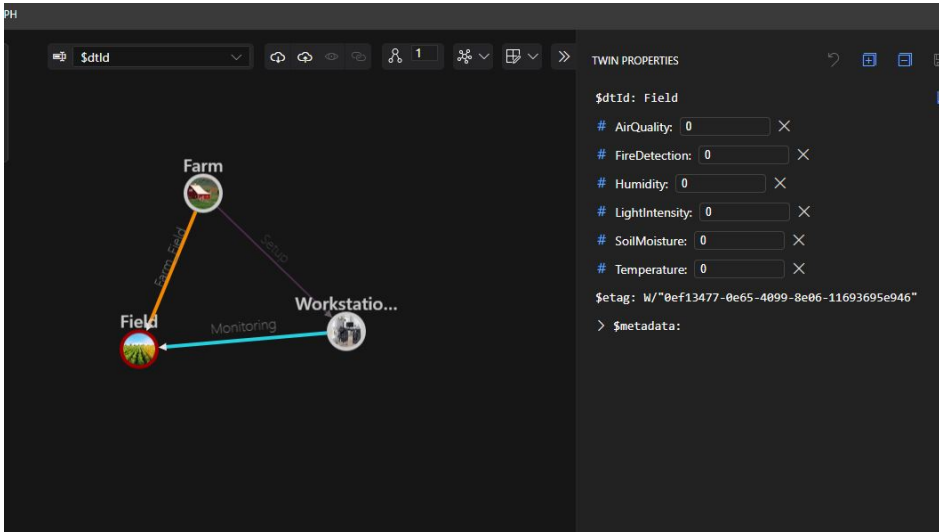

Figure 6.7: Azure Digital Twin Explorer Graph Overview (No Values Updated By default zero indication)

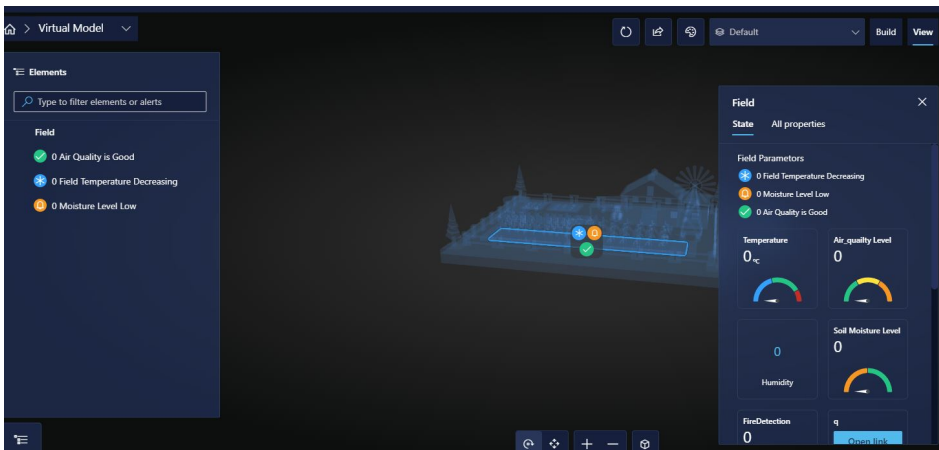
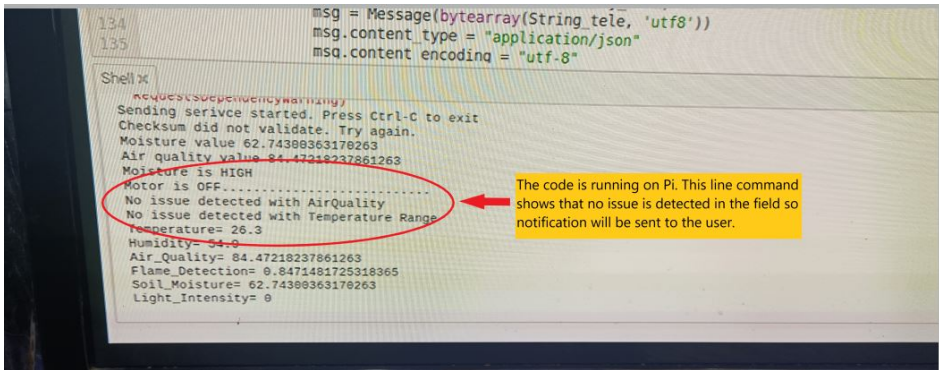

Figure 6.8: Azure Digital Twin 3d scene Overview (No Values updated: system model values updates if Explorer Graph is updated)

## 6.1.2 Updated/Final Analyses and Results

Results of the system after system hardware(Hardware is enabled) is established.



```
134 msg = Message(bytearray(String_tele, 'utf8'))
135 msg.content_type = "application/json"
msg.content_encoding = "utf-8"

Shell %
newusbdependencywarning
Sending service started, Press Ctrl-C to exit
Checksum did not validate. Try again.
Moisture value 62.74388363178263
Air quality value 84.47218237861263
Moisture is HIGH
Motor is OFF.....
No issue detected with AirQuality
No issue detected with Temperature Range
Temperature= 26.3
Humidity= 54.9
Air_Quality= 84.47218237861263
Flame_Detection= 0.8471481725318365
Soil_Moisture= 62.74388363178263
Light_Intensity= 0
```

The code is running on Pi. This line command shows that no issue is detected in the field so notification will be sent to the user.

Figure 6.9: RBPI4 Code status: Running

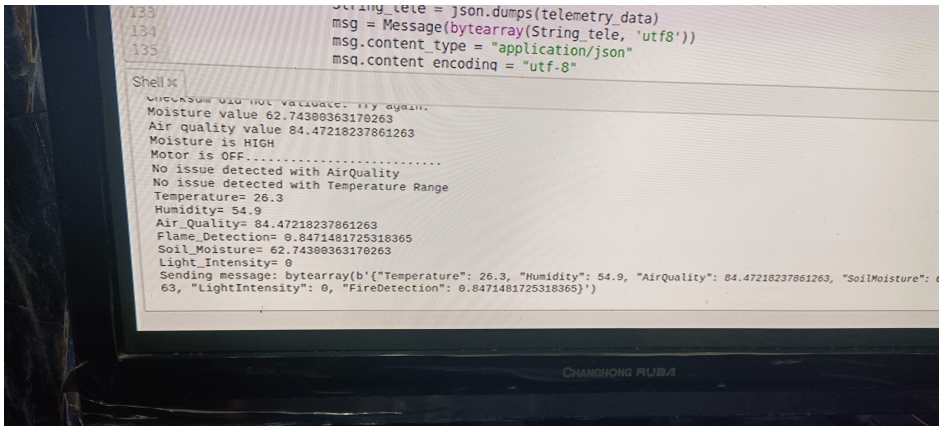

```
133 String_tele = json.dumps(telemetry_data)
134 msg = Message(bytearray(String_tele, 'utf8'))
135 msg.content_type = "application/json"
msg.content_encoding = "utf-8"

Shell %
Checksum did not validate. Try again.
Moisture value 62.74388363178263
Air quality value 84.47218237861263
Moisture is HIGH
Motor is OFF.....
No issue detected with AirQuality
No issue detected with Temperature Range
Temperature= 26.3
Humidity= 54.9
Air_Quality= 84.47218237861263
Flame_Detection= 0.8471481725318365
Soil_Moisture= 62.74388363178263
Light_Intensity= 0
Sending message: bytearray(b'{"Temperature": 26.3, "Humidity": 54.9, "AirQuality": 84.47218237861263, "SoilMoisture": 62.74388363178263, "LightIntensity": 0, "FireDetection": 0.8471481725318365}')
```

Figure 6.10: RBPI4 Code status: Running

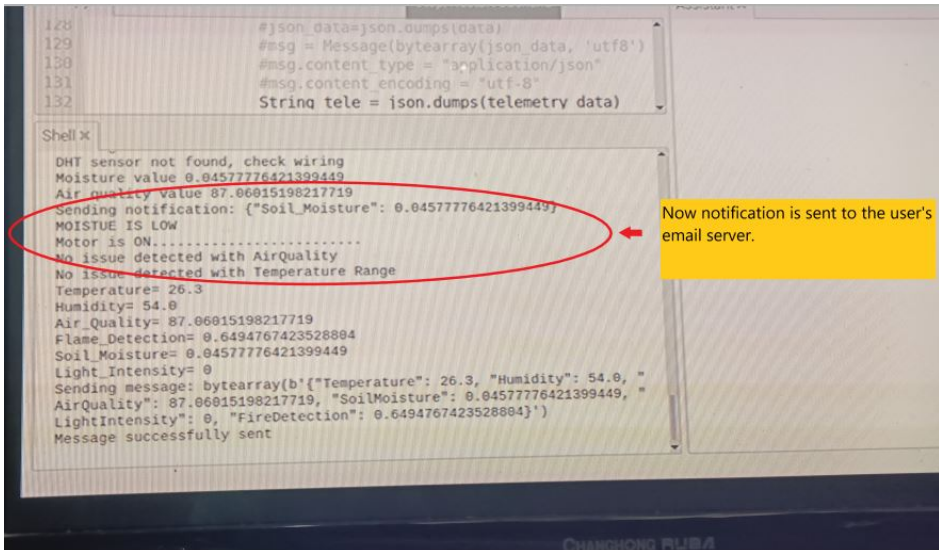

Figure 6.11: RBPI4 Code status: Running (Sending Notification)

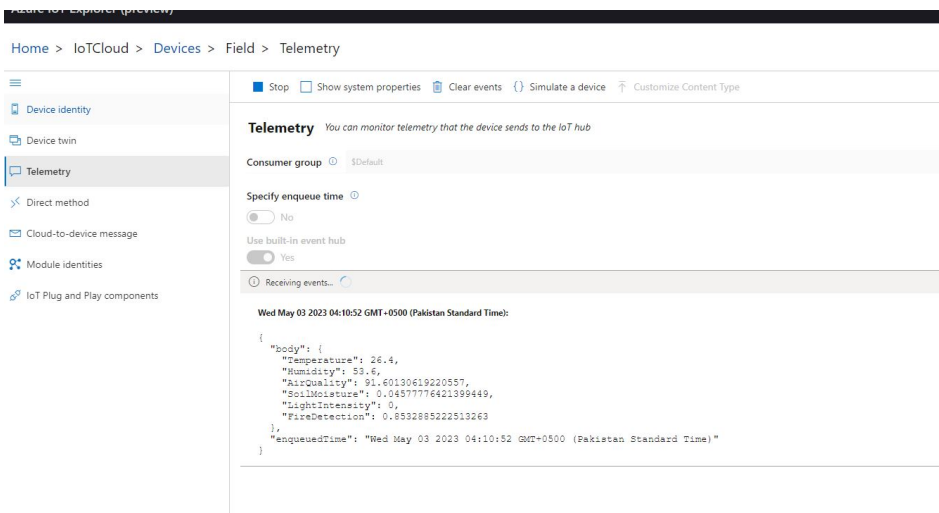

Figure 6.12: DeviceId:Field Azure IoT Explorer (Message Read)

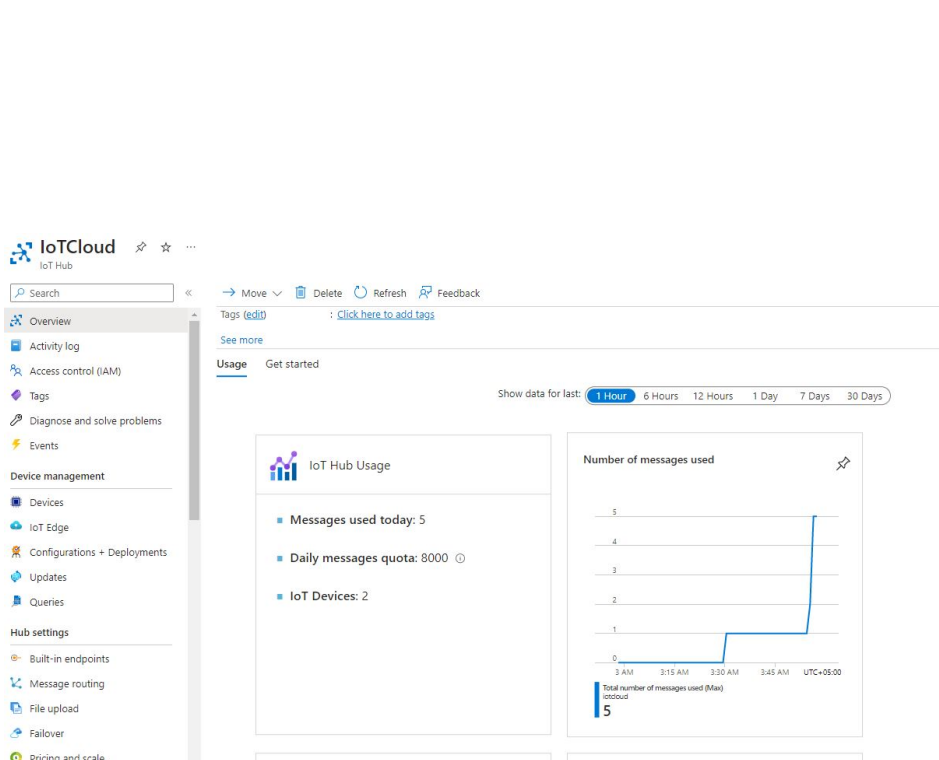

Figure 6.13: IOTHub Overview (Message Read)

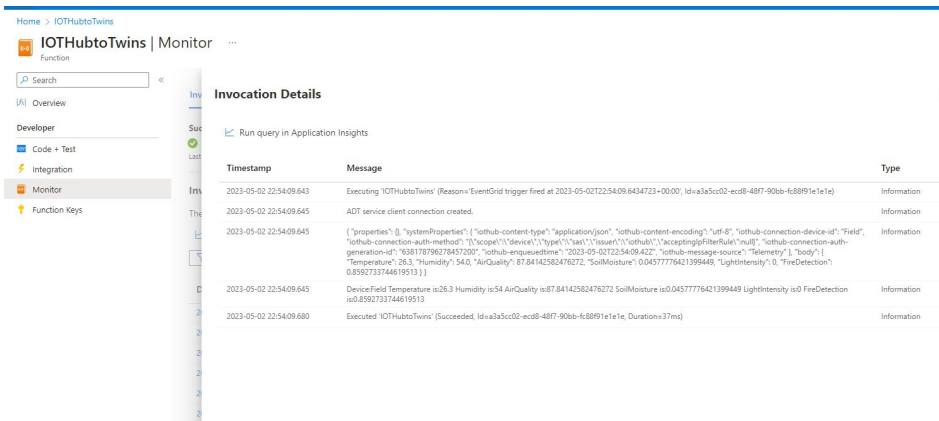

Figure 6.14: Azure Function App to transfer telemetry to Azure Explorer (Message Read)

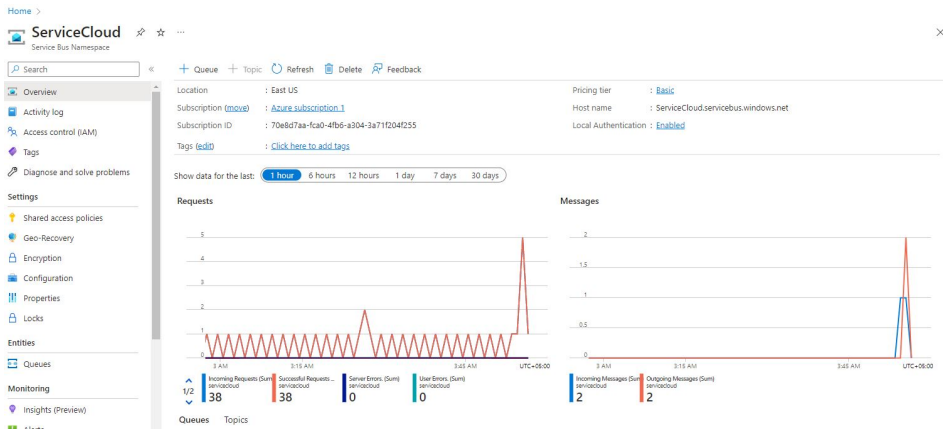

Figure 6.15: Service Bus Event Notifier Overview (Messages Read)

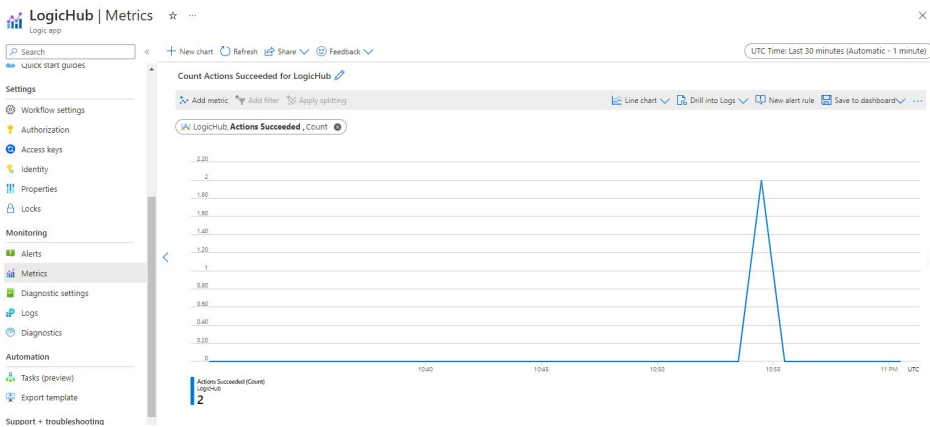

Figure 6.16: Logic Hub Metrics Overview (Message Read)

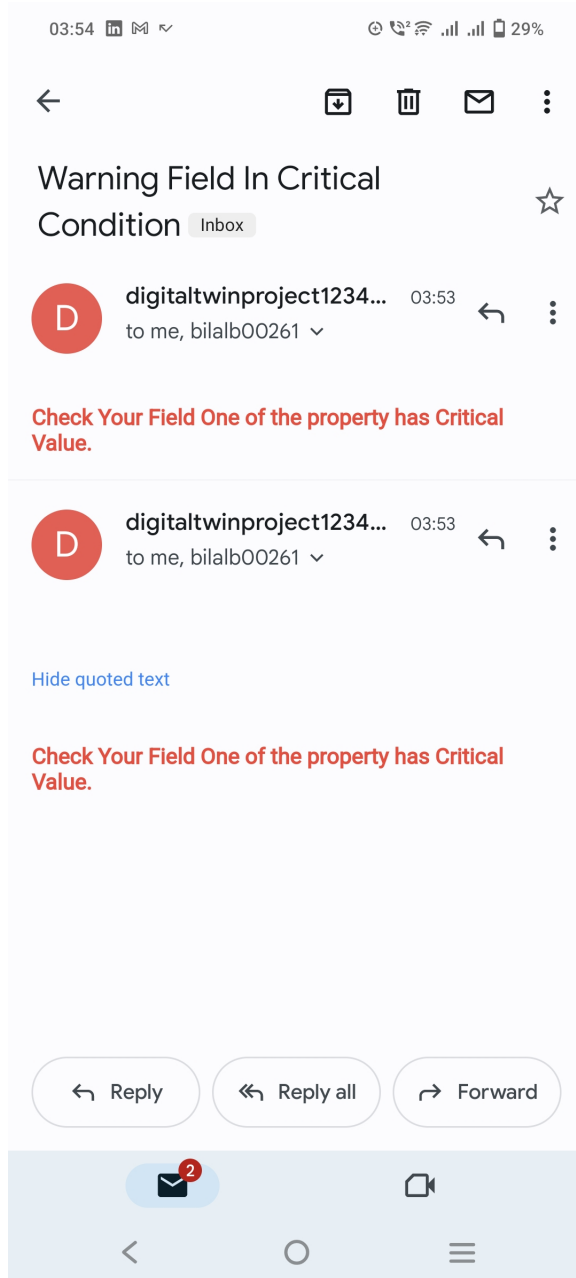

Figure 6.17: Received Notification Screenshots

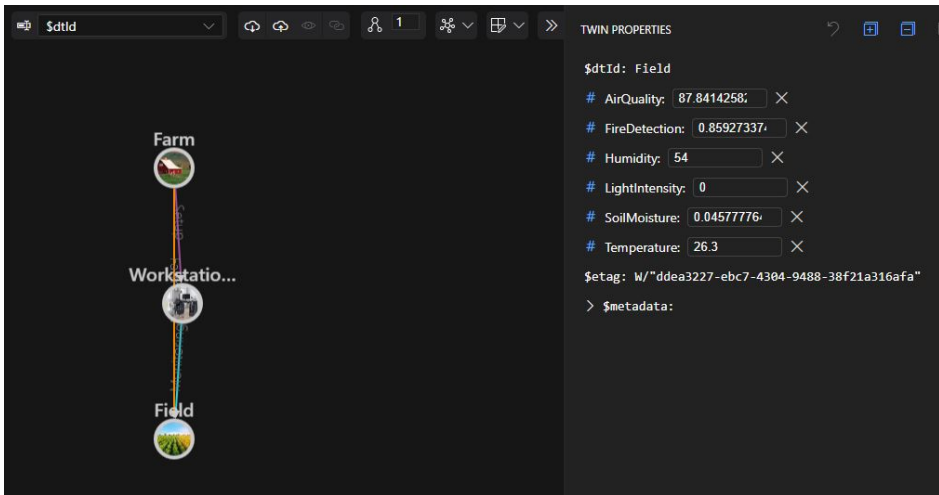

Figure 6.18: Azure Digital Twin Explorer Graph Overview (Values Updated By default zero indication)

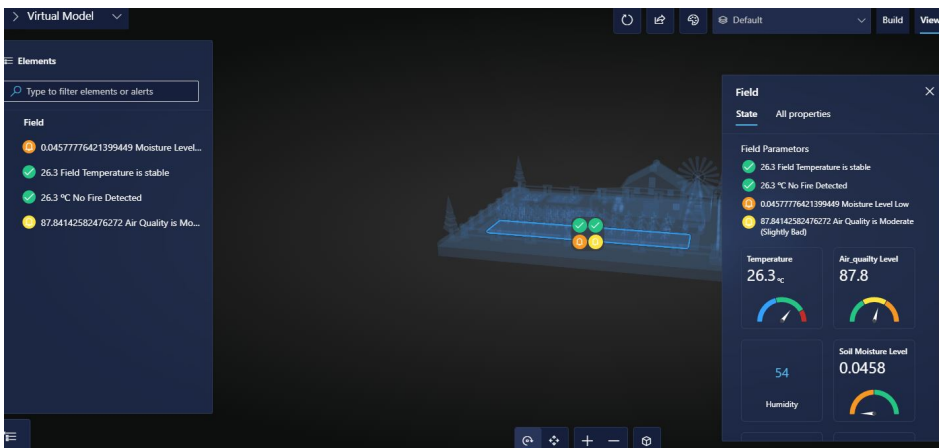

Figure 6.19: Azure Digital Twin 3d scene Overview(Values updated: system model values update if Explorer Graph is updated)

# Chapter 7

## Conclusion



We have applied the concept of Digital Twin in the agricultural sector to minimise losses during crop production. Our technology works like smart IoT-based sensors connected to the field to monitor the outcome. However, this digital twin technology improves the project's outcome, which is 3d visualization(virtual Model based upon physical product/environment) and better management by the continuous monitoring system. The sensor data coming from our Pi module is sent to Software known as "Azure Digital Twin" Service, and through that, an "IOTHUB Cloud server" is created to read that telemetry (sensors values in real-time) Data. Then we created another service known as "Azure Function App" to read Event data(Event is where data is being recorded and can be called through other services when in need) correctly and send real-time sensor values to the 3d Model. We define the rules and conditions in the 3d Model to observe the perimeter changes when they occur in Field. Other Services such as "Logic App", "Service Bus", and "SMTP Protocol" for notification service are being send to the user. This technology continues to evolve and is major evolution to industrial 4.0 technology. We have tried to accomplish this project to a certain degree, but improvement and advancement in this domain through time and effort can be used for further development.

# References

- [1] Noramalina Abdullah, Noor Aerina Binti Durani, Mohamad Farid Bin Shari, King Soon Siong, Vicky Kong Wei Hau, Wong Ngei Siong, and Ir Khairul Azman Ahmad. Towards smart agriculture monitoring using fuzzy systems. *IEEE Access*, 9:4097–4111, 2020.
- [2] 2019. <https://static.raspberrypi.org/files/product-briefs/Raspberry-Pi-4-Product-Brief.pdf>.
- [3] soil-moisture-sensor-module. <https://components101.com/modules/soil-moisture-sensor-module>.
- [4] gas-sensor for air quality-module. <https://components101.com/sensors/mq135-gas-sensor-for-air-quality>.
- [5] Dht-22 module. <https://components101.com/sensors/dht22-pinout-specs-datasheet>.

- [6] Flame sensor module. <https://www.pcboard.ca/flame-sensor-module>.
- [7] Electroduino.com. Ldr sensor module. <https://www.electroduino.com/ldr-sensor-module-how-ldr-sensor-works/>.
- [8] Ads-1115(adc) pinout configuration. <https://rb.gy/dyaxp0>.
- [9] Relay switch basic information and specs. <https://rb.gy/3xy18v>.
- [10] <https://raspberrypi4u.blogspot.com/2017/12/raspberry-pi-iot-firebase-realtimedatabase.html>.
- [11] Flame sensor module. <https://www.electroduino.com/ir-infrared-flame-sensor-module/>.
- [12] Cor Verdouw, Bedir Tekinerdogan, Adrie Beulens, and Sjaak Wolfert. Digital twins in smart farming. *Agricultural Systems*, 189:103046, 2021.
- [13] FAOSTAT FAO et al. Food and agriculture organization of the united nations. *Rome*, URL: <http://faostat.fao.org>, 2018.
- [14] Maulshree Singh, Evert Fuenmayor, Eoin P Hinchy, Yuansong Qiao, Niall Murray, and Declan Devine. Digital twin: Origin to future. *Applied System Innovation*, 4(2):36, 2021.
- [15] <https://www.amazon.com/dp/B09GKZ71PJ/?tag=sac-000002-20>.
- [16] [https://store.nerokas.co.ke/index.php?route=product/product&product\\_id=2050](https://store.nerokas.co.ke/index.php?route=product/product&product_id=2050).
- [17] <https://www.walmart.com/ip/10Ft-3Prong-AC-Power-Cord-Cable-for-Acer-Asus-HP-Dell-Lenovo-164759902>.

- [18] <https://www.electronicrecyclingaustralia.com.au/product/refurbished-keyboard-and-mouse-combo/>.
- [19] <https://ubuntu.com/download/raspberry-pi>.

# Appendix A

## User Manual

## A.1 RB-PI4 External Information

This section gives insights for raspberry pi 4 (RB-PI4) pinout configuration and information regarding important libraries to add before start working on raspberry pi 4.

### A.1.1 RB-PI4 Data-sheets and pin-out board



Raspberry Pi 4 Model B Datasheet  
Copyright Raspberry Pi (Trading) Ltd. 2019

Symbol	Parameter	Minimum	Maximum	Unit
VIN	5V Input Voltage	-0.5	6.0	V

Table 2: Absolute Maximum Ratings

Please note that VDD\_IO is the GPIO bank voltage which is tied to the on-board 3.3V supply rail.

Symbol	Parameter	Conditions	Minimum	Typical	Maximum	Unit
$V_{IL}$	Input low voltage <sup>a</sup>	VDD_IO = 3.3V	-	-	TBD	V
$V_{IH}$	Input high voltage <sup>a</sup>	VDD_IO = 3.3V	TBD	-	-	V
$I_{IL}$	Input leakage current	TA = +85°C	-	-	TBD	μA
$C_{IN}$	Input capacitance	-	-	TBD	-	pF
$V_{OL}$	Output low voltage <sup>b</sup>	VDD_IO = 3.3V, IOL = -2mA	-	-	TBD	V
$V_{OH}$	Output high voltage <sup>b</sup>	VDD_IO = 3.3V, IOH = 2mA	TBD	-	-	V
$I_{OL}$	Output low current <sup>c</sup>	VDD_IO = 3.3V, VO = 0.4V	TBD	-	-	mA
$I_{OH}$	Output high current <sup>c</sup>	VDD_IO = 3.3V, VO = 2.3V	TBD	-	-	mA
$R_{PU}$	Pullup resistor	-	TBD	-	TBD	kΩ
$R_{PD}$	Pulldown resistor	-	TBD	-	TBD	kΩ

<sup>a</sup> Hysteresis enabled

<sup>b</sup> Default drive strength (8mA)

<sup>c</sup> Maximum drive strength (16mA)

Table 3: DC Characteristics

Pin Name	Symbol	Parameter	Minimum	Typical	Maximum	Unit
Digital outputs	$t_{rise}$	10-90% rise time <sup>a</sup>	-	TBD	-	ns
Digital outputs	$t_{fall}$	90-10% fall time <sup>a</sup>	-	TBD	-	ns

<sup>a</sup> Default drive strength, CL = 5pF, VDD\_IO = 3.3V

Table 4: Digital I/O Pin AC Characteristics

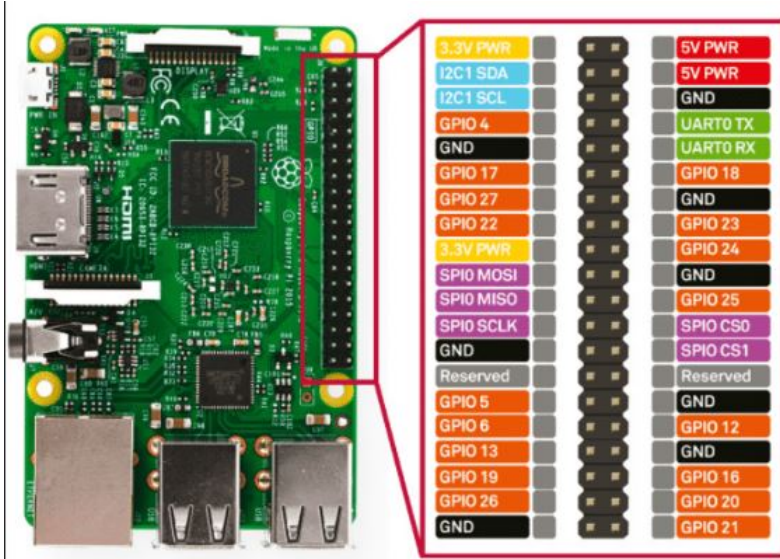

5.1.2 GPIO Alternate Functions

GPIO	Default Pull	ALT0	ALT1	ALT2	ALT3	ALT4	ALT5
0	High	SDA0	SA5	PCLK	SPI3_CEO_N	TXD2	SDA6
1	High	SCL0	SA4	DE	SPI3_MISO	RXD2	SCL6
2	High	SDA1	SA3	LCD_VSYNC	SPI3_MOSI	CTS2	SDA3
3	High	SCL1	SA2	LCD_HSYNC	SPI3_SCLK	RTS2	SCL3
4	High	GPCLK0	SA1	DPLD0	SPI4_CEO_N	TXD3	SDA3
5	High	GPCLK1	SA0	DPLD1	SPI4_MISO	RXD3	SCL3
6	High	GPCLK2	SOE_N	DPLD2	SPI4_MOSI	CTS3	SDA4
7	High	SPI0_CEO_N	SWE_N	DPLD3	SPI4_SCLK	RTS3	SCL4
8	High	SPI0_CEO_N	SD0	DPLD4	-	TXD4	SDA4
9	Low	SPI0_MISO	SD1	DPLD5	-	RXD4	SCL4
10	Low	SPI0_MOSI	SD2	DPLD6	-	CTS4	SDA5
11	Low	SPI0_SCLK	SD3	DPLD7	-	RTS4	SCL5
12	Low	PWM0	SD4	DPLD8	SPI5_CEO_N	TXD5	SDA5
13	Low	PWM1	SD5	DPLD9	SPI5_MISO	RXD5	SCL5
14	Low	TXD0	SD6	DPLD10	SPI5_MOSI	CTS5	TXD1
15	Low	RXD0	SD7	DPLD11	SPI5_SCLK	RTS5	RXD1
16	Low	FL0	SD8	DPLD12	CTS0	SPI1_CEO_N	CTS1
17	Low	FL1	SD9	DPLD13	RTS0	SPI1_CEO_N	RTS1
18	Low	PCM_CLK	SD10	DPLD14	SPI6_CEO_N	SPI1_CEO_N	PWM0
19	Low	PCM_FS	SD11	DPLD15	SPI6_MISO	SPI1_MISO	PWM1
20	Low	PCM_DIN	SD12	DPLD16	SPI6_MOSI	SPI1_MOSI	GPCLK0
21	Low	PCM_DOUT	SD13	DPLD17	SPI6_SCLK	SPI1_SCLK	GPCLK1
22	Low	SD0_CLK	SD14	DPLD18	SD1_CLK	ARM_TRST	SDA6
23	Low	SD0_CMD	SD15	DPLD19	SD1_CMD	ARM_RTCK	SCL6
24	Low	SD0_DAT0	SD16	DPLD20	SD1_DAT0	ARM_TDO	SPI3_CEO_N
25	Low	SD0_DAT1	SD17	DPLD21	SD1_DAT1	ARM_TCK	SPI4_CEO_N
26	Low	SD0_DAT2	TE0	DPLD22	SD1_DAT2	ARM_TDI	SPI5_CEO_N
27	Low	SD0_DAT3	TE1	DPLD23	SD1_DAT3	ARM_TMS	SPI6_CEO_N

Table 5: Raspberry Pi 4 GPIO Alternate Functions

---

### 5.1.3 Display Parallel Interface (DPI)

A standard parallel RGB (DPI) interface is available the GPIOs. This up-to-24-bit parallel interface can support a secondary display.

### 5.1.4 SD/SDIO Interface

The Pi4B has a dedicated SD card socket which supports 1.8V, DDR50 mode (at a peak bandwidth of 50 Megabytes / sec). In addition, a legacy SDIO interface is available on the GPIO pins.

## 5.2 Camera and Display Interfaces

The Pi4B has 1x Raspberry Pi 2-lane MIPI CSI Camera and 1x Raspberry Pi 2-lane MIPI DSI Display connector. These connectors are backwards compatible with legacy Raspberry Pi boards, and support all of the available Raspberry Pi camera and display peripherals.

## 5.3 USB

The Pi4B has 2x USB2 and 2x USB3 type-A sockets. Downstream USB current is limited to approximately 1.1A in aggregate over the four sockets.

## 5.4 HDMI

The Pi4B has 2x micro-HDMI ports, both of which support CEC and HDMI 2.0 with resolutions up to 4Kp60.

## 5.5 Audio and Composite (TV Out)

The Pi4B supports near-CD-quality analogue audio output and composite TV-output via a 4-ring TRS 'A/V' jack.

The analog audio output can drive 32 Ohm headphones directly.

## 5.6 Temperature Range and Thermals

The recommended ambient operating temperature range is 0 to 50 degrees Celcius.

To reduce thermal output when idling or under light load, the Pi4B reduces the CPU clock speed and voltage. During heavier load the speed and voltage (and hence thermal output) are increased. The internal governor will throttle back both the CPU speed and voltage to make sure the CPU temperature never exceeds 85 degrees C.

The Pi4B will operate perfectly well without any extra cooling and is designed for sprint performance - expecting a light use case on average and ramping up the CPU speed when needed (e.g. when loading a webpage). If a user wishes to load the system continually or operate it at a high temperature at full performance, further cooling may be needed.



## A.1.2 RB-PI4 OS(Ubuntu) and important libraries

If you need to install Ubuntu on your Raspberry Pi 4, you can follow these steps:

Download the Ubuntu Server image for Raspberry Pi from the official website [19].

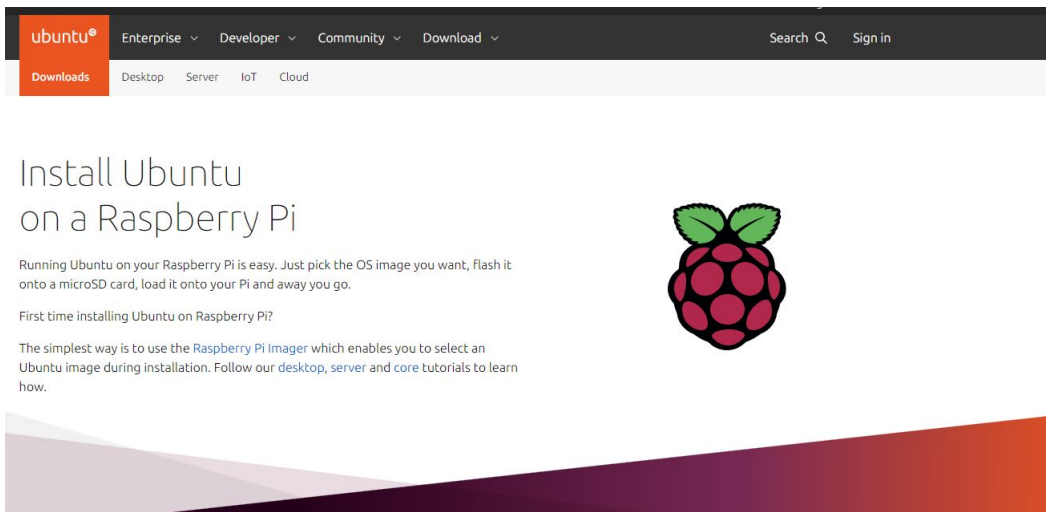

1. Insert the micro-SD card into your computer and use a tool like Etcher to flash the Ubuntu image onto the card.
2. Once the flashing process is complete, eject the micro-SD card from your computer and insert it into your Raspberry Pi 4.
3. Connect your Raspberry Pi to a monitor, keyboard, and mouse, and power it on.
4. Follow the on-screen instructions to set up Ubuntu on your Raspberry Pi.

5. Once Ubuntu is set up, you can open a terminal window and start writing Python code using the built-in os library.









### **Important Libraries to add :-**

- `sudo pip install adafruit-blinka`
- `sudo pip install adafruit-circuitpython-dht`
- `sudo pip install adafruit-circuitpython-ads1x15`
- `sudo pip install numpy`
- `sudo pip install azure-iot-device`
- `sudo pip install azure-iot-device-aiotools`
- `sudo pip install azure-iot-hub-service-client`

## A.2 Azure Platform Services used and Software Usage

Given below is an general figure table in which we have mentioned the services and software being used for the completion of the project.

**Note:-**” Other Services can be employed to meet your needs.”

Platform	Services Used	Software & Coding used
	 Azure Digital Twin  Function  Storage  Azure Data Explorer  Azure IoT Hub  Azure Logic Apps  Azure Service Bus  Azure Event Grid  Azure Event Hub  Azure Dashboard  Azure Monitor	 Visual Studio  Visual Studio Code  HTML  python  JavaScript  C#  Bash  blender  GLB

# Final Digital Twin Thesis (E119)

## ORIGINALITY REPORT

7%

SIMILARITY INDEX

2%

INTERNET SOURCES

3%

PUBLICATIONS

3%

STUDENT PAPERS

## PRIMARY SOURCES

1	"Digital Twin Technology", Wiley, 2022 Publication	1%
2	Submitted to Monash University Student Paper	1%
3	Submitted to University of Southern Mississippi Student Paper	1%
4	"IoT for Defense and National Security", Wiley, 2022 Publication	<1%
5	Submitted to National School of Business Management NSBM, Sri Lanka Student Paper	<1%
6	"International Conference on Intelligent Data Communication Technologies and Internet of Things (ICICI) 2018", Springer Science and Business Media LLC, 2019 Publication	<1%
7	Submitted to Higher Education Commission Pakistan Student Paper	<1%
8	Submitted to University College London	

<1 %

---

9 Bob Familiar, Jeff Barnes. "Business in Real-Time Using Azure IoT and Cortana Intelligence Suite", Springer Science and Business Media LLC, 2017  
Publication

<1 %

---

10 Cor Verdouw, Bedir Tekinerdogan, Adrie Beulens, Sjaak Wolfert. "Digital twins in smart farming", Agricultural Systems, 2021  
Publication

<1 %

---

11 publisher.uthm.edu.my  
Internet Source

<1 %

---

12 repo.ust.edu.sd:8080  
Internet Source

<1 %

---

13 www.controleng.com  
Internet Source

<1 %

---

14 eprints.utm.edu.my  
Internet Source

<1 %

---

15 pdffox.com  
Internet Source

<1 %

---

16 www.coursehero.com  
Internet Source

<1 %

---

17 Submitted to Middle East College of Information Technology  
Student Paper

<1 %

---

18	Submitted to University of Central England in Birmingham Student Paper	<1 %
19	Submitted to University of Liverpool Student Paper	<1 %
20	Submitted to Wellington Institute of Technology Student Paper	<1 %
21	ir.unimas.my Internet Source	<1 %
22	research.nsu.ru Internet Source	<1 %
23	Submitted to The University of the West of Scotland Student Paper	<1 %
24	Submitted to Birkbeck College Student Paper	<1 %
25	Submitted to Manukau Institute of Technology Student Paper	<1 %
26	Guillermo Guillen. "Sensor Projects with Raspberry Pi", Springer Science and Business Media LLC, 2019 Publication	<1 %
27	Dhiraj Sunehra, M. Srinidhi. "Implementation of Smart Urban Farming using Raspberry Pi, Arduino and Node-RED Platform", 2020 IEEE International	<1 %

# Conference for Innovation in Technology (INOCON), 2020

Publication

28

Elisa Negri, Luca Fumagalli, Marco Macchi. "A Review of the Roles of Digital Twin in CPS-based Production Systems", Procedia Manufacturing, 2017

Publication

<1 %

29

K. Mohaideen Abdul Kadhar, G. Anand. "Data Science with Raspberry Pi", Springer Science and Business Media LLC, 2021

Publication

<1 %

30

Submitted to Segi University College

Student Paper

<1 %

31

[eng-sci.udmercy.edu](http://eng-sci.udmercy.edu)

Internet Source

<1 %

32

Neenu Johnson, M.B. Santosh Kumar, T Dhannia. "A study on the significance of smart IoT sensors and Data science in Digital agriculture", 2020 Advanced Computing and Communication Technologies for High Performance Applications (ACCTHPA), 2020

Publication

<1 %

33

"Nanoelectronics, Circuits and Communication Systems", Springer Science and Business Media LLC, 2019

Publication

<1 %

34 "Smart Trends in Computing and Communications", Springer Science and Business Media LLC, 2023  $<1\%$   
Publication

---

35 Behrang Ashtari Talkhestani, Tobias Jung, Benjamin Lindemann, Nada Sahlab, Nasser Jazdi, Wolfgang Schloegl, Michael Weyrich. "An architecture of an Intelligent Digital Twin in a Cyber-Physical Production System", at - Automatisierungstechnik, 2019  $<1\%$   
Publication

---

36 Pankaj Sharma, Pritam ., Sohil Sisodiya. "Sustainable agriculture : An IoT based case-study", TARU Journal of Sustainable Technologies and Computing, 2019  $<1\%$   
Publication

---

37 Pushpita Chatterjee, Debashis Das, Danda Rawat. "Securing Financial Transactions: Exploring the Role of Federated Learning and Blockchain in Credit Card Fraud Detection", Institute of Electrical and Electronics Engineers (IEEE), 2023  $<1\%$   
Publication

---

38 Salvatore Cavalieri, Salvatore Gambadoro. "Proposal of Mapping Digital Twins Definition Language to Open Platform Communications Unified Architecture", Sensors, 2023  $<1\%$   
Publication

---



39 Thabet Righi, Mohammed Charaf Eddine Meftah. "Towards an Organizational Approach for an Advanced Agricultural Information System (AAIS)", International Journal of Organizational and Collective Intelligence, 2022  
Publication <1 %

---

40 ebin.pub  
Internet Source <1 %

---

41 pubag.nal.usda.gov  
Internet Source <1 %

---

42 www.keyestudio.com  
Internet Source <1 %

---

43 www.mdpi.com  
Internet Source <1 %

---

44 "Proceedings of International Joint Conference on Computational Intelligence", Springer Science and Business Media LLC, 2020  
Publication <1 %

---

Exclude quotes Off

Exclude matches Off

Exclude bibliography On